



ALL NEW
CBR
150R

OWNER'S MANUAL

- WARRANTY POLICY
- LIST OF SERVICE PROVIDERS



CBR150R

REGISTER NOW!!!
FOR A HASSLE FREE
WARRANTY

This manual should be considered a permanent part of the motorcycle and should remain with the motorcycle when it is resold.

This publication includes the latest production information available before printing. Honda Motor Co., Ltd. reserves the right to make changes at any time without notice and without incurring any obligation.

No part of this publication may be reproduced without written permission.

The vehicle pictured in this owner's manual may not match your actual vehicle.

Welcome

Congratulations on your purchase of a new Honda motorcycle. Your selection of a Honda makes you part of a worldwide family of satisfied customers who appreciate Honda's reputation for building quality into every product.

To ensure your safety and riding pleasure:

- Read this owner's manual carefully.
- Follow all recommendations and procedures contained in this manual.
- Pay close attention to safety messages contained in this manual and on the motorcycle.

- The following codes in this manual indicate the country.
- The illustrations here in are based on the CBR150R PH type.

Country Codes

Code	Country
------	---------

CBR150R

PH	Philippines
III PH	Philippines
V PH	Philippines

A Few Words About Safety

Your safety, and the safety of others, is very important. Operating this motorcycle safely is an important responsibility.

To help you make informed decisions about safety, we have provided operating procedures and other information on safety labels and in this manual. This information alerts you to potential hazards that could hurt you or others.

Of course, it is not practical or possible to warn you about all hazards associated with operating or maintaining a motorcycle. You must use your own good judgement.

You will find important safety information in a variety of forms, including:

- Safety labels on the motorcycle
- Safety Messages preceded by a safety alert symbol  and one of three signal words: DANGER, WARNING, or CAUTION.

These signal words mean:

DANGER

You **WILL** be **KILLED** or **SERIOUSLY HURT** if you don't follow instructions.

WARNING

You **CAN** be **KILLED** or **SERIOUSLY HURT** if you don't follow instructions.

CAUTION

You **CAN** be **HURT** if you don't follow instructions.

Other important information is provided under the following titles:

NOTICE Information to help you avoid damage to your motorcycle, other property, or the environment.

Contents

Motorcycle Safety P. 2

Operation Guide P. 12

Maintenance P. 31

Troubleshooting P. 77

Information P. 94

Specifications P. 106

Index P. 109

Motorcycle Safety

This section contains important information for safe riding of your motorcycle.
Please read this section carefully.

Safety Guidelines	P. 3
Safety Precautions	P. 6
Riding Precautions	P. 7
Accessories & Modifications	P. 10
Loading	P. 11

Safety Guidelines

Follow these guidelines to enhance your safety:

- Perform all routine and regular inspections specified in this manual.
- Stop the engine and keep sparks and flame away before filling the fuel tank.
- Do not run the engine in enclosed or partly enclosed areas. Carbon monoxide in exhaust gases is toxic and can kill you.

Always Wear a Helmet

It's a proven fact: helmets and protective apparel significantly reduce the number and severity of head and other injuries. So always wear an approved motorcycle helmet and protective apparel. 📖 P. 6

Before Riding

Make sure that you are physically fit, mentally focused and free of alcohol and drugs. Check that you and your passenger are both wearing an approved motorcycle helmet and protective apparel. Instruct your passenger on holding onto the seat strap or your waist, leaning with you in turns, and keeping their feet on the footpegs, even when the motorcycle is stopped.

Take Time to Learn & Practice

Even if you have ridden other motorcycles, practice riding in a safe area to become familiar with how this motorcycle works and handles, and to become accustomed to the motorcycle's size and weight.

Safety Guidelines

Ride Defensively

Always pay attention to other vehicles around you, and do not assume that other drivers see you. Be prepared to stop quickly or perform an evasive maneuver.

Make Yourself Easy to See

Make yourself more visible, especially at night, by wearing bright reflective clothing, positioning yourself so other drivers can see you, signaling before turning or changing lanes, and using your horn when necessary.

Ride within Your Limits

Never ride beyond your personal abilities or faster than conditions warrant. Fatigue and inattention can impair your ability to use good judgement and ride safely.

Don't Drink and Ride

Alcohol and riding don't mix. Even one alcoholic drink can reduce your ability to respond to changing conditions, and your reaction time gets worse with every additional drink. Don't drink and ride, and don't let your friends drink and ride either.

Keep Your Honda in Safe Condition

It's important to keep your motorcycle properly maintained and in safe riding condition. Inspect your motorcycle before every ride and perform all recommended maintenance. Never exceed load limits (➤ P. 11), and do not modify your motorcycle or install accessories that would make your motorcycle unsafe (➤ P. 10).

If You are Involved in a Crash

Personal safety is your first priority. If you or anyone else has been injured, take time to assess the severity of the injuries and whether it is safe to continue riding. Call for emergency assistance if needed. Also follow applicable laws and regulations if another person or vehicle is involved in the crash.

If you decide to continue riding, first turn the ignition switch to the OFF position, and evaluate the condition of your motorcycle. Inspect for fluid leaks, check the tightness of critical nuts and bolts, and check the handlebars, control levers, brakes, and wheels. Ride slowly and cautiously.

Your motorcycle may have suffered damage that is not immediately apparent. Have your motorcycle thoroughly checked at a qualified service facility as soon as possible.

Carbon Monoxide Hazard

Exhaust contains poisonous carbon monoxide, a colourless, odorless gas. Breathing carbon monoxide can cause loss of consciousness and may lead to death.

If you run the engine in confined or even partly enclosed area, the air you breathe could contain a dangerous amount of carbon monoxide. Never run your motorcycle inside a garage or other enclosure.

WARNING

Running the engine of your motorcycle while in an enclosed or even partially enclosed area can cause a rapid build-up of toxic carbon monoxide gas.

Breathing this colourless, odorless gas can quickly cause unconsciousness and lead to death.

Only run your motorcycle's engine when it is located in a well ventilated area outdoors.

Safety Precautions

Safety Precautions

- Ride cautiously and keep your hands on the handlebars and feet on the footpegs.
- Keep passenger's hands onto the seat strap or your waist, passenger's feet on the footpegs while riding.
- Always consider the safety of your passenger, as well as other drivers and riders.

Protective Apparel

Make sure that you and any passenger are wearing an approved motorcycle helmet, eye protection, and high-visibility protective clothing. Ride defensively in response to weather and road conditions.

■ Helmet

Safety-standard certified, high-visibility, correct size for your head.

- Must fit comfortably but securely, with the chin strap fastened.

- Face shield with unobstructed field of vision or other approved eye protection.

⚠ WARNING

Not wearing a helmet increases the chance of serious injury or death in a crash.

Make sure that you and any passenger always wear an approved helmet and protective apparel.

■ Gloves

Full-finger leather gloves with high abrasion resistance.

■ Boots or Riding Shoes

Sturdy boots with non-slip soles and ankle protection.

■ Jacket and Trousers

Protective, highly visible, long-sleeved jacket and durable trousers for riding (or a protective suit).

Riding Precautions

Running-in Period

During the first 500 km (300 miles) of running, follow these guidelines to ensure your motorcycle's future reliability and performance.

- Avoid full-throttle starts and rapid acceleration.
- Avoid hard braking and rapid down-shifts.
- Ride conservatively.

Brakes

Observe the following guidelines:

- Avoid excessively hard braking and downshifting.
 - ▶ Sudden braking can reduce the motorcycle's stability.
 - ▶ Where possible, reduce speed before turning; otherwise you risk sliding out.
- Exercise caution on low traction surfaces.
 - ▶ The tyres slip more easily on such surfaces and braking distances are longer.
- Avoid continuous braking.
 - ▶ Repeated braking, such as when descending long, steep slopes can seriously overheat the brakes, reducing their effectiveness. Use engine braking with intermittent use of the brakes to reduce speed.
- For full braking effectiveness, operate both the front and rear brakes together.

Riding Precautions

■ Engine Braking

Engine braking helps slow your motorcycle down when you release the throttle. For further slowing action, downshift to a lower gear. Use engine braking with intermittent use of the brakes to reduce speed when descending long, steep slopes.

■ Wet or Rainy Conditions

Road surfaces are slippery when wet, and wet brakes further reduce braking efficiency. Exercise extra caution when braking in wet conditions.

If the brakes get wet, apply the brakes while riding at low speed to help them dry.

Parking

- Park on a firm, level surface.
- If you must park on a slight incline or loose surface, park so that the motorcycle cannot move or fall over.
- Make sure that high-temperature parts cannot come into contact with flammable materials.
- Do not touch the engine, muffler, brakes and other high-temperature parts until they cool down.
- To reduce the likelihood of theft, always lock the handlebars and remove the key and close the shutter when leaving the motorcycle unattended.
Use of an anti-theft device is also recommended.

Parking with the Side Stand

1. Stop the engine.
2. Push the side stand down.

3. Slowly lean the motorcycle to the left until its weight rests on the side stand.
4. Turn the handlebars fully to the left.
 - ▶ Turning the handlebars to the right reduces stability and may cause the motorcycle to fall.
5. Turn the ignition switch to the LOCK position, remove the key and close the shutter. ➤ P. 22

Refuelling and Fuel Guidelines

Follow these guidelines to protect the engine and catalytic converter:

- Use only unleaded petrol.
- Use recommended octane number. Using lower octane petrol will result in decreased engine performance.
- Do not use fuels containing a high concentration of alcohol. ➤ P. 104
- Do not use stale or contaminated petrol or an oil/petrol mixture.
- Avoid getting dirt or water in the fuel tank.

Accessories & Modifications

We strongly advise that you do not add any accessories that were not specifically designed for your motorcycle by Honda or make modifications to your motorcycle from its original design. Doing so can make it unsafe. Modifying your motorcycle may also void your warranty and make your motorcycle illegal to operate on public roads and highways. Before deciding to install accessories on your motorcycle be certain the modification is safe and legal.

WARNING

Improper accessories or modifications can cause a crash in which you can be seriously hurt or killed.

Follow all instructions in this owner's manual regarding accessories and modifications.

Do not pull a trailer with, or attach a sidecar to, your motorcycle. Your motorcycle was not designed for these attachments, and their use can seriously impair your motorcycle's handling.

Loading

- Carrying extra weight affects your motorcycle's handling, braking and stability. Always ride at a safe speed for the load you are carrying.
- Avoid carrying an excessive load and keep within specified load limits.
Maximum weight capacity ➤ P. 106
- Tie all luggage securely, evenly balanced and close to the centre of the motorcycle.
- Do not place objects near the lights or the muffler.

WARNING

Overloading or improper loading can cause a crash and you can be seriously hurt or killed.

Follow all load limits and other loading guidelines in this manual.

Parts Location

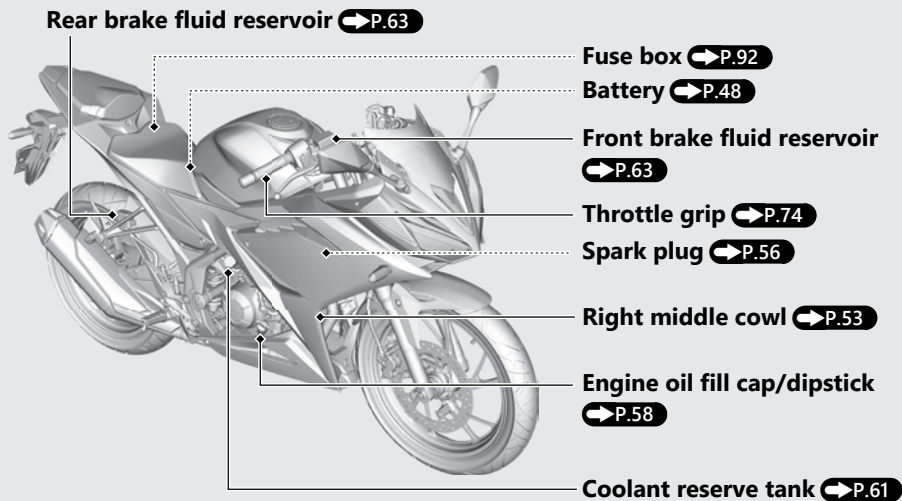

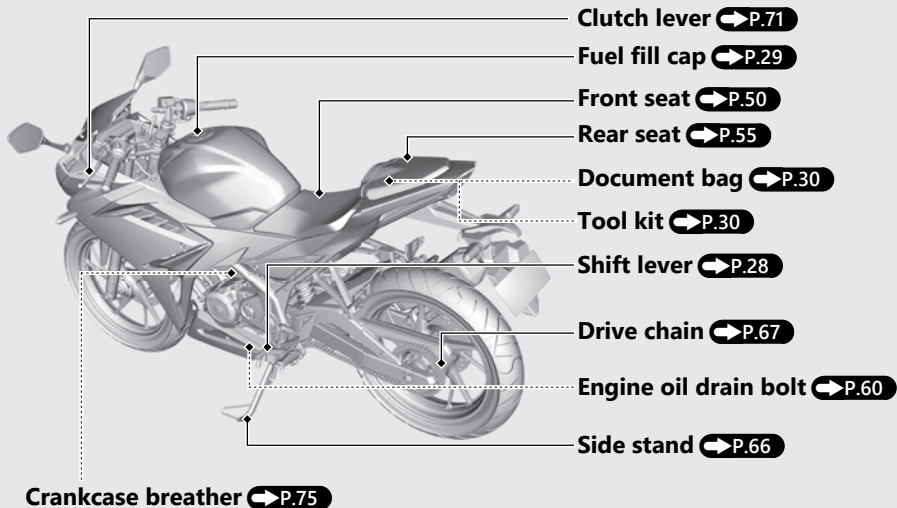

Instruments

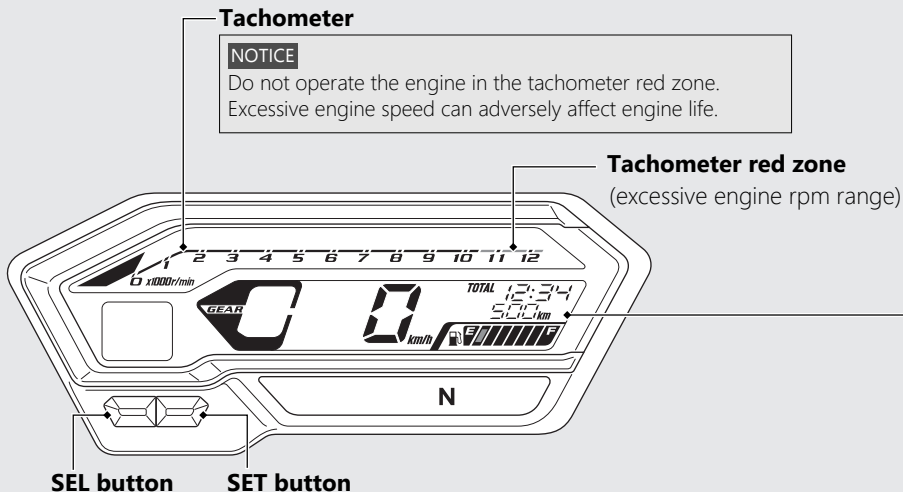

Display Check

When the ignition switch is turned on, all the mode and digital segments will show. If any part of these displays does not come on when it should, have your dealer check for problems.

Odometer [TOTAL] & Tripmeter [TRIP A/B] & Current fuel mileage & Average fuel mileage [AVG A/B] ➔ P.16

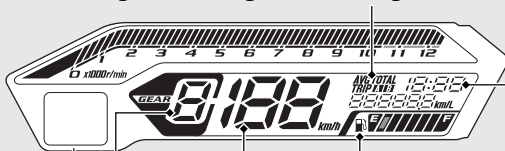

Clock (12-hour display)

To set the clock: ➔ P.19

Fuel gauge

Remaining fuel when only 1st (E) segment starts flashing: approximately 1.8 L (0.48 US gal, 0.40 Imp gal)

If the fuel gauge indicator flashes in a repeat pattern or turns off: ➔ P.81



Speedometer

Gear position indicator

The gear position is shown in the gear position indicator.

▶ "-" appears when the transmission is not shifted properly.

Instruments *(Continued)*

Odometer [TOTAL] & Tripmeter [TRIP A/B] & Current fuel mileage & Average fuel mileage [AVG A/B]

The SEL button switches between the odometer, tripmeter A, tripmeter B, current fuel mileage, average fuel mileage A and average fuel mileage B.

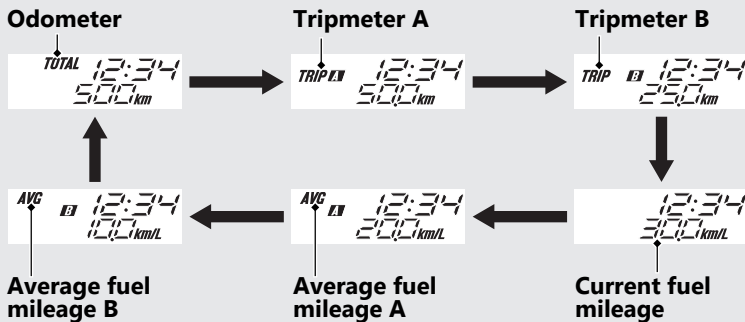

| Odometer [TOTAL]

Total distance ridden. When "-----" is displayed, go to your dealer for service.

| Tripmeter [TRIP A/B]

Distance ridden since tripmeter was reset. When "-----" is displayed, go to your dealer for service.

To reset the tripmeter:  **P.18**

| Current fuel mileage

Displays the current or instant fuel mileage.
Display range: 0.0 to 99.9 km/L

- Initial display: "--.-" is displayed.
- When your speed is less than 6 km/h (4 mph): "--.-" is displayed.
- More than 99.9 km/L: "99.9" is displayed.

When "--.-" is displayed except for the above-mentioned cases, go to your dealer for service.

| Average fuel mileage [AVG A/B]

The average fuel mileage A will be based on tripmeter A. The average fuel mileage A since tripmeter A was reset.

The average fuel mileage B will be based on tripmeter B. The average fuel mileage B since tripmeter B was reset.

Display range: 0.0 to 99.9 km/L

- Initial display: "--.-" is displayed.
- More than 99.9 km/L: "99.9" is displayed.
- When the tripmeter A or B is reset: "--.-" is displayed.

When "--.-" is displayed except for the above-mentioned cases, go to your dealer for service.

To reset the average fuel mileage:

 **P.18**

Instruments *(Continued)*

To reset the tripmeter [TRIP A/B] and average fuel mileage [AVG A/B]

To reset the tripmeter A and average fuel mileage A together, press and hold the SET button while the tripmeter A or average fuel mileage A is displayed.

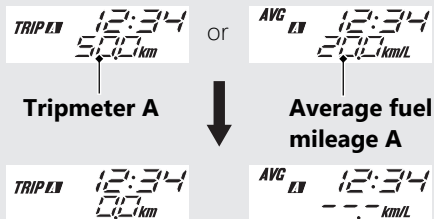

To reset the tripmeter B and average fuel mileage B together, press and hold the SET button while the tripmeter B or average fuel mileage B is displayed.

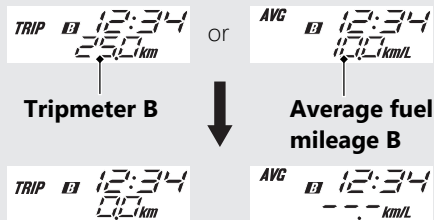

To set the clock

- 1 Turn the ignition switch on.
- 2 Press and hold the SEL and the SET buttons until the hour digits start flashing.

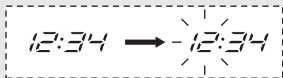

- 3 Press the SEL button until the desired hour is displayed.
 - ▶ Press and hold the SEL button to advance the hour fast.

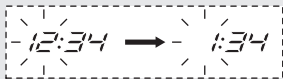

- 4 Press the SET button. The minute digits start flashing.

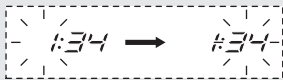

- 5 Press the SEL button until the desired minute is displayed.
 - ▶ Press and hold the SEL button to advance the minute fast.



- 6 Press the SET button. The clock is set.
 - ▶ The time can also be set by turning the ignition switch off.
 - ▶ The display will stop flashing automatically and the adjustment will be cancelled if the button is not pressed for about 30 seconds.

Indicators

If one of these indicators does not come on when it should, have your dealer check for problems.

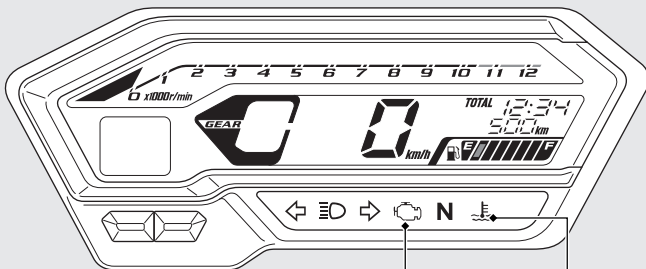

PGM-FI (Programmed Fuel Injection) malfunction indicator lamp (MIL)

Comes on briefly when the ignition switch is turned on.

If it comes on while engine is running:

 **P.80**

High coolant temperature indicator

Comes on briefly when the ignition switch is turned on.

If it comes on while riding:

 **P.79**

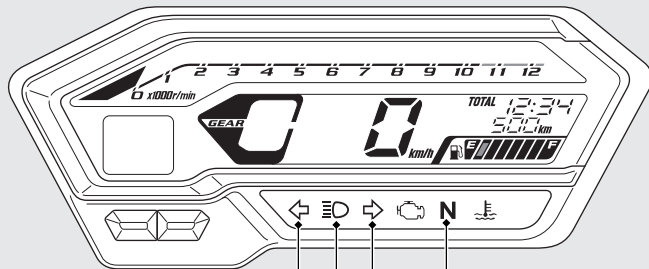

N Neutral indicator

Comes on when the transmission is in Neutral.



⇒ Right turn signal indicator

≡ High beam indicator

⇐ Left turn signal indicator

Switches

Headlight dimmer switch

-  : High beam
-  : Low beam

Start button

Horn button

PASS Passing light control switch

Flashes the high beam headlight.

Turn signal switch

- ▶ Pressing the switch turns the turn signal off.

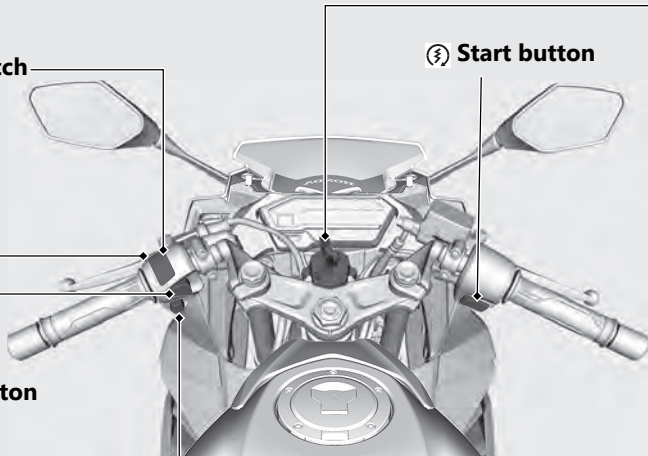

Ignition Switch

Switches the electrical system on/off, locks the steering.
▶ Key can be removed when in the OFF or LOCK position.

ON
Turns electrical system on for starting/riding.

OFF
Turns engine off.

LOCK
Locks steering.

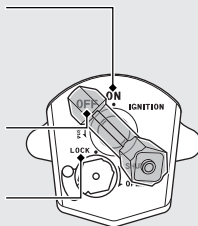

Switches *(Continued)*

Steering Lock

Lock the steering when parking to help prevent theft.

A U-shaped wheel lock or similar device is also recommended.

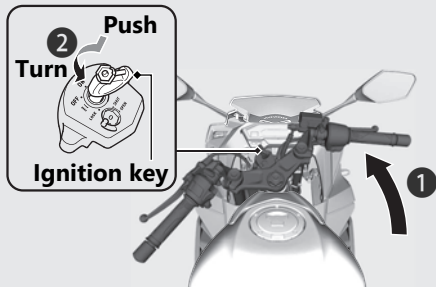

Locking

- 1 Turn the handlebars all the way to the left.
- 2 Push the key down, and turn the ignition switch to the LOCK position.
 - ▶ Jiggle the handlebars if the lock is difficult to engage.
- 3 Remove the key.

Unlocking

Insert the key, push it in, and turn the ignition switch to the OFF position.

Shutter

The ignition switch for this motorcycle is equipped with a shutter. After parking the motorcycle, close the shutter for theft prevention.

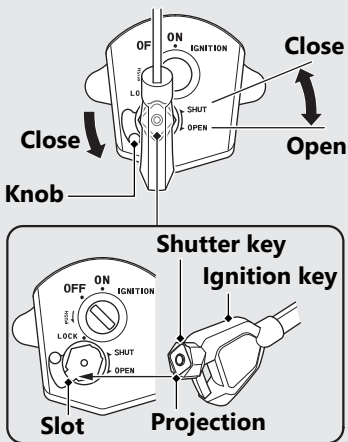

Close

- 1 Remove the ignition key from the ignition switch.
- 2 Align the projection of the shutter key with the slot of the shutter, and turn the shutter key counterclockwise.
 - ▶ You can also close the shutter by moving the knob downward without the shutter key.
- 3 Remove the key.

Open

Align the projection of the shutter key with the slot of the shutter, and turn the shutter key clockwise.

Starting the Engine

Start your engine using the following procedure, regardless of whether the engine is cold or warm.

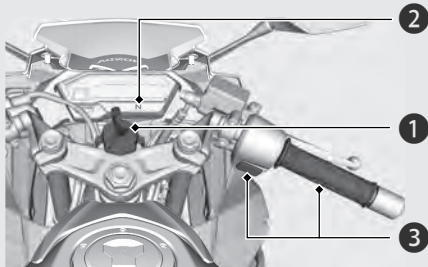

NOTICE

- If the engine does not start within 5 seconds, turn the ignition switch to the OFF position and wait 10 seconds before trying to start the engine again to recover battery voltage.
- Extended fast idling and revving the engine can damage the engine, and the exhaust system.

Consult your dealer for advice if you plan to ride your motorcycle at an altitude above 2,500 m (8,000 feet).

NOTICE

If the motorcycle is transported to a place 2,000 m (6,500 feet) higher or lower than the start point, you may not be able to achieve sufficient engine performance at the new altitude. Consult your dealer before transporting your motorcycle.

- 1 Turn the ignition switch to the ON position.
- 2 Shift the transmission to Neutral (N indicator to come on).
- 3 With the throttle closed, press the start button.
Release the start button as soon as the engine starts.

If you cannot start a warm engine:
Rotate the throttle $1/8$ – $1/4$ turn while
starting the engine.

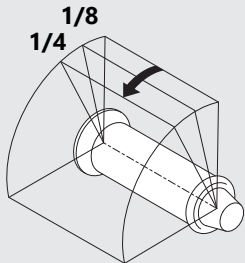

If the engine does not start:

- ① Open the throttle fully and press the start button for 5 seconds.
- ② Repeat the normal starting procedure.
- ③ If the engine starts, open the throttle slightly if idling is unstable.
- ④ If the engine does not start, wait 10 seconds before trying step ① & ② again.

If Engine Will Not Start → P.78

Shifting Gears

Your motorcycle transmission has 6 forward gears in a one-down, five-up shift pattern.

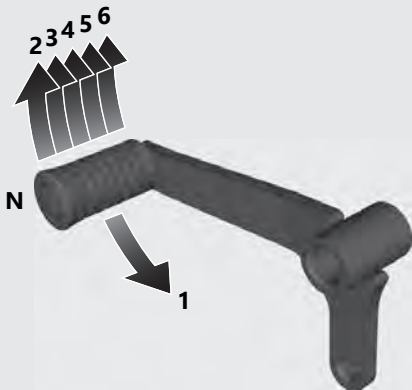

Refuelling

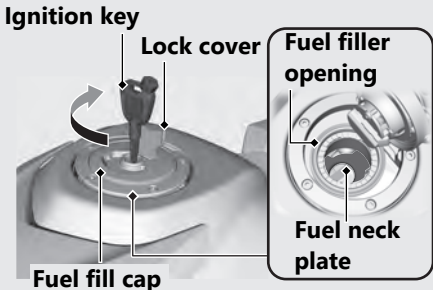

Do not fill with fuel above the filler neck plate.

Fuel type: Unleaded petrol only

Fuel octane number: Your motorcycle is designed to use Research Octane Number (RON) 88 or higher.

Tank capacity: 12.0 L (3.17 US gal, 2.64 Imp gal)

Refuelling and Fuel Guidelines ➔ P.9

Opening the Fuel Fill Cap

Open the lock cover, insert the ignition key, and turn it clockwise to open the cap.

Closing the Fuel Fill Cap

- 1 After refuelling, push the fuel fill cap closed until it locks.
- 2 Remove the key and close the lock cover.
 - ▶ The key cannot be removed if the cap is not locked.

⚠ WARNING

Petrol is highly flammable and explosive. You can be burned or seriously injured when handling fuel.

- Stop the engine, and keep heat, sparks, and flame away.
- Handle fuel only outdoors.
- Wipe up spills immediately.

Storage Equipment

The helmet holder, helmet set wire (in the tool kit), tool kit, and document bag are located under the rear seat.

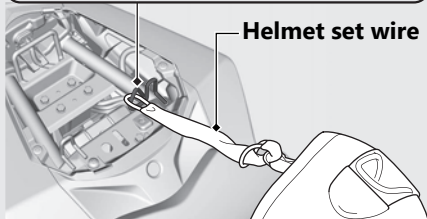
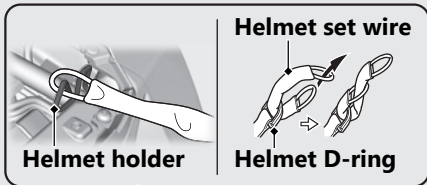

► Use the helmet holder only when parked.

▮ **Removing the Rear Seat** ➔ P.55

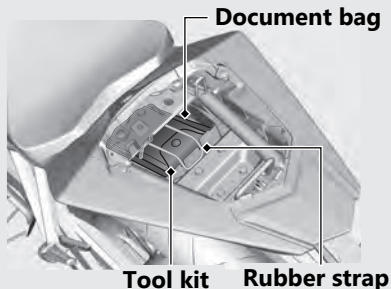

⚠ WARNING

Riding with a helmet attached to the holder can interfere with the rear wheel or suspension and could cause a crash in which you can be seriously hurt or killed.

Use the helmet holder only while parked. Do not ride with a helmet secured by the holder.

Maintenance

Please read "Importance of Maintenance" and "Maintenance Fundamentals" carefully before attempting any maintenance. Refer to "Specifications" for service data.

Importance of Maintenance	P. 32	Brakes	P. 63
Maintenance Schedule	P. 33	Side Stand	P. 66
Maintenance Fundamentals	P. 36	Drive Chain	P. 67
Tool Kit	P. 47	Clutch	P. 71
Removing & Installing Body Components ..	P. 48	Throttle	P. 74
Battery	P. 48	Crankcase Breather	P. 75
Clip	P. 49	Other Adjustments	P. 76
Front Seat	P. 50	Adjusting the Headlight Aim	P. 76
Harness Band Clip	P. 52		
Right Middle Cowl	P. 53		
Rear Seat	P. 55		
Spark Plug	P. 56		
Engine Oil	P. 58		
Coolant	P. 61		

Importance of Maintenance

Importance of Maintenance

Keeping your motorcycle well-maintained is absolutely essential to your safety and to protect your investment, obtain maximum performance, avoid breakdowns, and reduce air pollution. Maintenance is the owner's responsibility. Be sure to inspect your motorcycle before each ride, and perform the periodic checks specified in the Maintenance Schedule. ➤ P. 33

⚠ WARNING

Improperly maintaining your motorcycle or failing to correct a problem before you ride can cause a crash in which you can be seriously hurt or killed.

Always follow the inspection and maintenance recommendations and schedules in this owner's manual.

Maintenance Safety

Always read the maintenance instructions before you begin each task, and make sure that you have the tools, parts, and skills required. We cannot warn you of every conceivable hazard that can arise in performing maintenance. Only you can decide whether or not you should perform a given task.

Follow these guidelines when performing maintenance.

- Stop the engine and remove the key.
- Place your motorcycle on a firm, level surface using the side stand or a maintenance stand to provide support.
- Allow the engine, muffler, brakes, and other high-temperature parts to cool before servicing as you can get burned.
- Run the engine only when instructed, and do so in a well-ventilated area.

Maintenance Schedule

The maintenance schedule specifies the maintenance requirements necessary to ensure safe, dependable performance, and proper emission control.

Maintenance work should be performed in accordance with Honda's standards and specifications by properly trained and equipped technicians. Your dealer meets all of these requirements. Keep an accurate record of maintenance to help ensure that your motorcycle is properly maintained. Make sure that whomever performs the maintenance completes this record.

All scheduled maintenance is considered a normal owner operating cost and will be charged to you by your dealer. Retain all receipts. If you sell the motorcycle, these receipts should be transferred with the motorcycle to the new owner.

Honda recommends that your dealer should road test your motorcycle after each periodic maintenance is carried out.

Maintenance Schedule

Items		Pre-ride Check ➡ P. 36	Frequency *1							Annual Check	Regular Replace	Refer to page	
			× 1,000 km	1	6	12	18	24	30				36
			× 1,000 mi	0.6	4	8	12	16	20				24
Fuel Line	🔧			I	I	I	I	I	I	I		-	
Fuel Level		I										29	
Throttle Operation	🔧	I		I	I	I	I	I	I	I		74	
Air Cleaner *2	🔧					R				R		46	
Crankcase Breather *3				C	C	C	C	C	C	C		75	
Spark Plug				I	R	I	R	I	R			56	
Valve Clearance	🔧							I				-	
Engine Oil		I		R	R	R	R	R	R	R	R	58	
Engine Oil Strainer Screen	🔧					C		C		C		-	
Engine Idle Speed	🔧		I	I	I	I	I	I	I	I		-	
Radiator Coolant *4		I				I		I		I	3 Years	61	
Cooling System	🔧					I		I		I		-	





Maintenance Level

- 🔧 : Intermediate. We recommend service by your dealer, unless you have the necessary tools and are mechanically skilled. Procedures are provided in an official Honda Shop Manual.
- 🔧 : Technical. In the interest of safety, have your motorcycle serviced by your dealer.

Maintenance Legend

- I : Inspect (clean, adjust, lubricate, or replace, if necessary)
- C : Clean
- L : Lubricate
- R : Replace

Maintenance Schedule

Items	Pre-ride Check P. 36	Frequency *1								Annual Check	Regular Replace	Refer to page
		× 1,000 km	1	6	12	18	24	30	36			
		× 1,000 mi	0.6	4	8	12	16	20	24			
Drive Chain	I			Every 500 km (300 mi): I L								67
Brake Fluid *4	I			I	I	I	I	I	I	I	2 Years	63
Brake Pads Wear	I			I	I	I	I	I	I	I		64
Brake System			I	I	I	I	I	I	I	I		36
Brakelight Switch				I	I	I	I	I	I	I		65
Headlight Aim				I	I	I	I	I	I	I		76
Lights/Horn	I											-
Clutch System	I		I	I	I	I	I	I	I	I		71
Side Stand				I	I	I	I	I	I	I		66
Suspension				I	I	I	I	I	I	I		-
Nuts, Bolts, Fasteners			I		I		I		I	I		-
Wheels/Tyres		I		I	I	I	I	I	I	I		43
Steering Head Bearings					I		I		I	I		-

Notes:

*1 : At higher odometer readings, repeat at the frequency interval established here.

*2 : Service more frequently when riding in unusually wet or dusty areas.

*3 : Service more frequently when riding in rain or at full throttle.

*4 : Replacement requires mechanical skill.

Pre-ride Inspection

To ensure safety, it is your responsibility to perform a pre-ride inspection and make sure that any problem you find is corrected. A pre-ride inspection is a must, not only for safety, but because having a breakdown, or even a flat tyre, can be a major inconvenience.

Check the following items before you get on your motorcycle:

- Fuel level - Fill fuel tank when necessary. ➤ P. 29
- Throttle - Check for smooth opening and full closing in all steering positions. ➤ P. 74
- Engine oil level - Add engine oil if necessary. Check for leaks. ➤ P. 58
- Coolant level - Add coolant if required. Check for leaks. ➤ P. 61
- Drive chain - Check condition and slack, adjust and lubricate if necessary. ➤ P. 67
- Brakes - Check operation; Front and Rear: check brake fluid level and pads wear. ➤ P. 63, ➤ P. 64
- Lights and horn - Check that lights, indicators and horn function properly.
- Clutch - Check operation; Adjust freeplay if necessary. ➤ P. 71
- Wheels and tyres - Check condition, air pressure and adjust if necessary. ➤ P. 43

Replacing Parts

Always use Honda Genuine Parts or their equivalents to ensure reliability and safety.

WARNING

Installing non-Honda parts may make your motorcycle unsafe and cause a crash in which you can be seriously hurt or killed.

Always use Honda Genuine Parts or equivalents that have been designed and approved for your motorcycle.

Battery

Your motorcycle has a maintenance-free type battery. You do not have to check the battery electrolyte level or add distilled water. Clean the battery terminals if they become dirty or corroded.

Do not remove the battery cap seals. There is no need to remove the cap when charging.

NOTICE

Your battery is a maintenance-free type and can be permanently damaged if the cap strip is removed.

WARNING

The battery gives off explosive hydrogen gas during normal operation.

A spark or flame can cause the battery to explode with enough force to kill or seriously hurt you.

Wear protective clothing and a face shield, or have a skilled mechanic do the battery servicing.

| Cleaning the Battery Terminals

1. Remove the battery. ➤ P. 48
2. If the terminals are starting to corrode and are coated with a white substance, wash with warm water and wipe clean.

3. If the terminals are heavily corroded, clean and polish the terminals with a wire brush or sandpaper. Wear safety glasses.

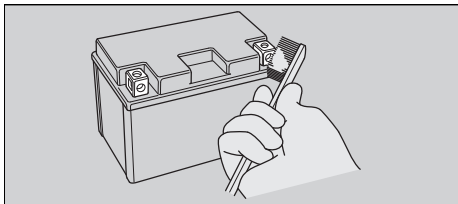

4. After cleaning, reinstall the battery.

The battery has a limited life span. Consult your dealer about when you should replace the battery. Always replace the battery with another maintenance-free battery of the same type.

NOTICE

Installing non-Honda electrical accessories can overload the electrical system, discharging the battery and possibly damaging the system.

Fuses

Fuses protect the electrical circuits on your motorcycle. If something electrical on your motorcycle stops working, check for and replace any blown fuses. 📄 P. 92

Inspecting and Replacing Fuses

Turn the ignition switch to the OFF position to remove and inspect fuses. If a fuse is blown, replace with a fuse of the same rating. For fuse ratings, see "Specifications." 📄 P. 108

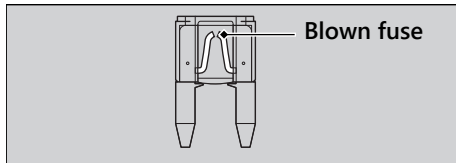

NOTICE

Replacing a fuse with one that has a higher rating greatly increases the chance of damage to the electrical system.

Maintenance Fundamentals

If a fuse fails repeatedly, you likely have an electrical fault. Have your motorcycle inspected by your dealer.

Engine Oil

Engine oil consumption varies and oil quality deteriorates according to riding conditions and time elapsed.

Check the engine oil level regularly, and add the recommended engine oil if necessary. Dirty oil or old oil should be changed as soon as possible.

Selecting the Engine Oil

For recommended engine oil, see "Specifications." P. 107

If you use non-Honda engine oil, check the label to make sure that the oil satisfies all of the following standards:

- JASO T 903 standard*1: MA
- SAE standard*2: 10W-30
- API classification*3: SG or higher

- *1. The JASO T 903 standard is an index for engine oils for 4-stroke motorcycle engines. There are two classes: MA and MB. For example, the following label shows the MA classification.

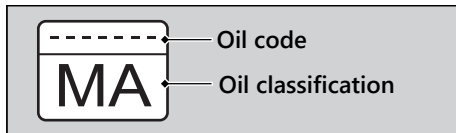

- *2. The SAE standard grades oils by their viscosity.
- *3. The API classification specifies the quality and performance rating of engine oils. Use SG or higher oils, excluding oils marked as "Energy Conserving" or "Resource Conserving" on the circular API service symbol.

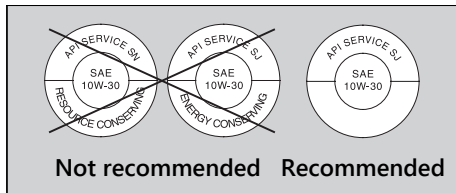

Brake Fluid

Do not add or replace brake fluid, except in an emergency. Use only fresh brake fluid from a sealed container. If you do add fluid, have the brake system serviced by your dealer as soon as possible.

NOTICE

Brake fluid can damage plastic and painted surfaces. Wipe up spills immediately and wash thoroughly.

Recommended brake fluid:

Honda DOT 3 or DOT 4 Brake Fluid or equivalent

Drive Chain

The drive chain must be inspected and lubricated regularly. Inspect the chain more frequently if you often ride on bad roads, ride at high speed, or ride with repeated fast acceleration. ➡ P. 67

If the chain does not move smoothly, makes strange noises, has damaged rollers, has loose pins, or kinks, have the chain inspected by your dealer.

Also inspect the drive sprocket and driven sprocket. If either has worn or damaged teeth, have the sprocket replaced by your dealer.

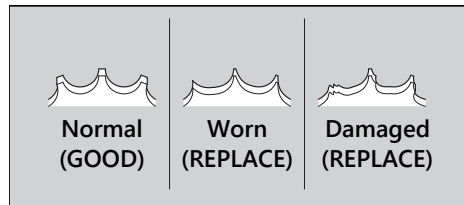

NOTICE

Use of a new chain with worn sprockets will cause rapid chain wear.

Maintenance Fundamentals

Cleaning and Lubricating

After inspecting the slack, clean the chain and sprockets while rotating the rear wheel. Use a dry cloth with high flash-point solvent. Use a soft brush if the chain is dirty.

After cleaning, wipe dry and lubricate with the recommended lubricant.

Recommended lubricant:

Drive chain lubricant

If not available, use SAE 80 or 90 gear oil.

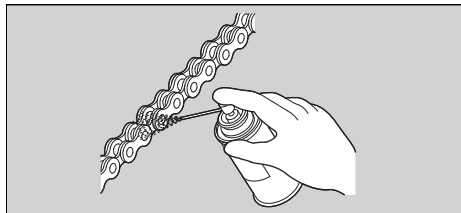

Never use petrol or low flash point solvents for cleaning the drive chain.

A fire or explosion could result.

Avoid getting lubricant on the brakes or tyres.

Avoid applying excess chain lubricant to prevent spray onto your clothes and the motorcycle.

Recommended Coolant

Use only genuine HONDA PRE-MIX COOLANT without diluting with water. Genuine HONDA PRE-MIX COOLANT is excellent at preventing corrosion and overheating.

The coolant should be inspected and replaced properly by following the maintenance schedule. ➤ P. 33

NOTICE

Using coolant not specified for aluminium engines or tap/mineral water can cause corrosion.

Crankcase Breather

Service more frequently when riding in rain, at full throttle, or after the motorcycle is washed or overturned. Service if the deposit level can be seen in the transparent section of the drain tube.

If the drain tube overflows, the air filter may become contaminated with engine oil causing poor engine performance. ➤ P. 75

Tyres (Inspecting/Replacing)

Checking the Air Pressure

Visually inspect your tyres and use an air pressure gauge to measure the air pressure at least once a month or any time you think the tyres look low. Always check air pressure when your tyres are cold.

Inspecting for Damage

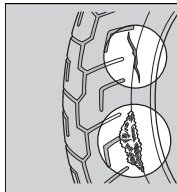

Inspect the tyres for cuts, slits, or cracks that exposes fabric or cords, or nails or other foreign objects embedded in the side of the tyre or the tread.

Also inspect for any unusual bumps or bulges in the side walls of the tyres.

Inspecting for Abnormal Wear

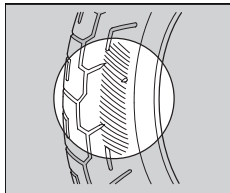

Inspect the tyres for signs of abnormal wear on the contact surface.

Inspecting Tread Depth

Inspect the tread wear indicators. If they become visible, replace the tyres immediately. For safe riding, you should replace the tyres when the minimum tread depth is reached.

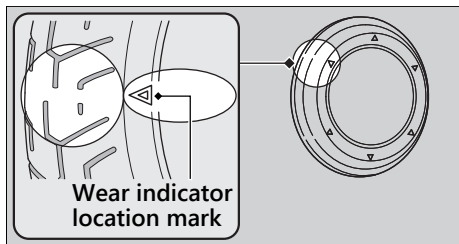

⚠️ WARNING

Riding on tyres that are excessively worn or improperly inflated can cause a crash in which you can be seriously hurt or killed.

Follow all instructions in this owner's manual regarding tyre inflation and maintenance.

Have your tyres replaced by your dealer. For recommended tyres, air pressure and minimum tread depth, see "Specifications."

➤ P. 107

Follow these guidelines whenever you replace tyres.

- Use the recommended tyres or equivalents of the same size, construction, speed rating, and load range.
- Have the wheel balanced with Honda Genuine balance weights or equivalent after the tyre is installed.
- Do not install a tube inside a tubeless tyre on this motorcycle. Excessive heat build-up can cause the tube to burst.
- Use only tubeless tyres on this motorcycle. The rims are designed for tubeless tyres, and during hard acceleration or braking, a tube-type tyre could slip on the rim and cause the tyre to rapidly deflate.

WARNING

Installing improper tyres on your motorcycle can adversely affect handling and stability, and can cause a crash in which you can be seriously hurt or killed.

Always use the size and type of tyres recommended in this owner's manual.

Maintenance Fundamentals

Air Cleaner

This motorcycle is equipped with a viscous type air cleaner element.

Air blow cleaning or any other cleaning can degrade the viscous element performance and cause the intake of dust.

Do not perform the maintenance. Should be serviced by your dealer.

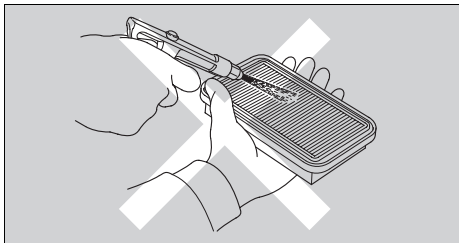

Tool Kit

The tool kit is stored under the rear seat.

➔ P. 55

You can perform some roadside repairs, minor adjustments and parts replacement with the tools contained in the kit.

- 10 × 14 mm Open end wrench
- Spark plug wrench
- 5 mm Hex wrench
- Helmet set wire

Removing & Installing Body Components

Battery

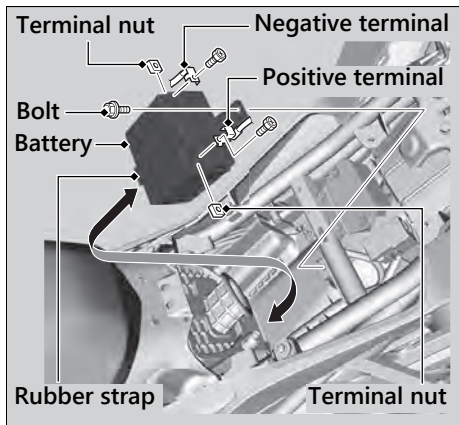

Removal

Make sure the ignition switch is in the OFF position.

1. Remove the front seat. ➤ P. 50

2. Remove the bolt.
3. Disconnect the negative \ominus terminal from the battery.
4. Disconnect the positive \oplus terminal from the battery.
5. Remove the battery taking care not to drop the terminal nuts.

Installation

Install the parts in the reverse order of removal. Always connect the positive \oplus terminal first. Make sure that bolts and nuts are tight.

Make sure the clock information is correct after the battery is reconnected. ➤ P. 19
For proper handling of the battery, see "Maintenance Fundamentals." ➤ P. 38
"Battery Goes Dead." ➤ P. 88

Clip

Removal



1. Press down on the centre pin to release the lock.
2. Pull the clip out of the hole.

Installation



1. Push the bottom of the centre pin.
2. Insert the clip into the hole.
3. Press down on the centre pin to lock the clip.

Front Seat

Removal

1. Remove the rear seat. ► P. 55
2. Remove the bolts and clips, and then pull the seat lock cover back and up.

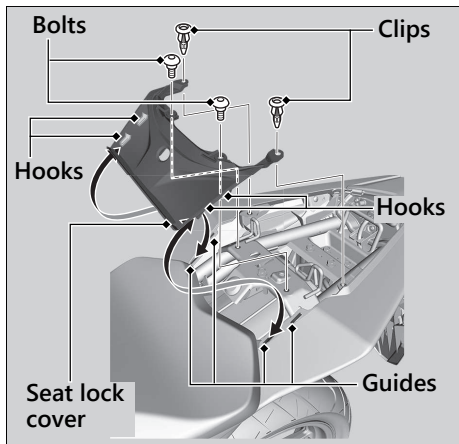

3. Remove the mounting bolts and collars, and then pull the front seat back and up.

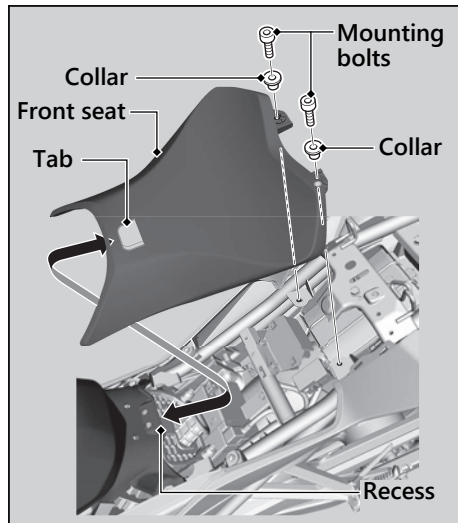

Installation

1. Install the front seat while inserting the tab into the recess.
2. Install the collars and mounting bolts.
3. Tighten the mounting bolts securely.
4. Install the seat lock cover while inserting the hooks into the guides.
5. Install and tighten the bolts.

Torque: 4.2 N·m (0.4 kgf·m, 3.1 lbf·ft)

6. Install the clips.
7. Install the rear seat.
Make sure that the seat is locked securely in position to pull it up lightly.

Harness Band Clip

Removal

Pull the harness band clip while pressing both side of the anchor.

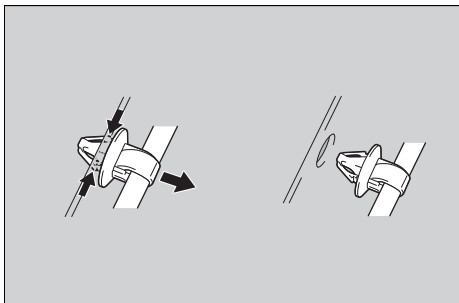

Installation

Install the harness band clip until it seats properly.

Right Middle Cowl

Removal

1. Remove the front seat. ► P. 50
2. Remove the clip. ► P. 49
3. Remove the bolts A and bolts B.

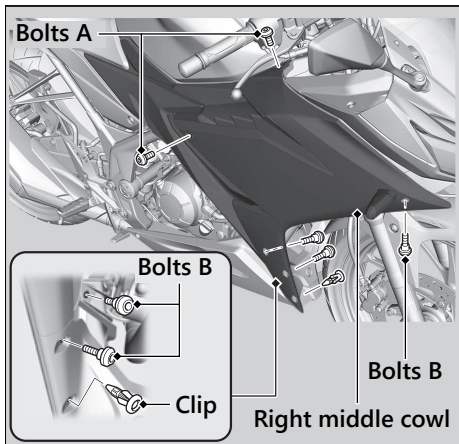

4. Release the tabs from the slots.
5. Release the prongs from the grommets.
6. Remove the right middle cowl while releasing the harness band clip. ► P. 52
 - Be careful not to damage the wire harness.
 - Be careful not to apply weight to the right middle cowl.

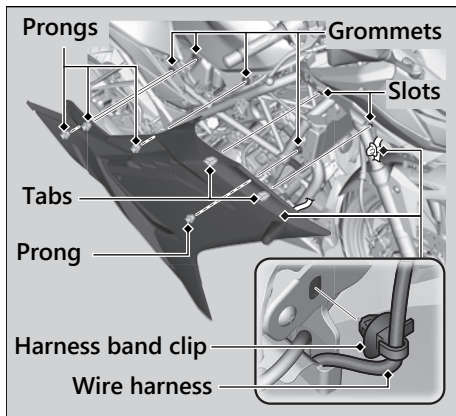

Installation

1. To install the right middle cowl, reverse the removal procedure.
2. Install and tighten the the bolts A securely.
3. Install and tighten the bolts B.

Torque: 4.2 N·m (0.4 kgf·m, 3.1 lbf·ft)

4. Install the clip
Check that the turn signals function properly after you install the right middle cowl.

Rear Seat

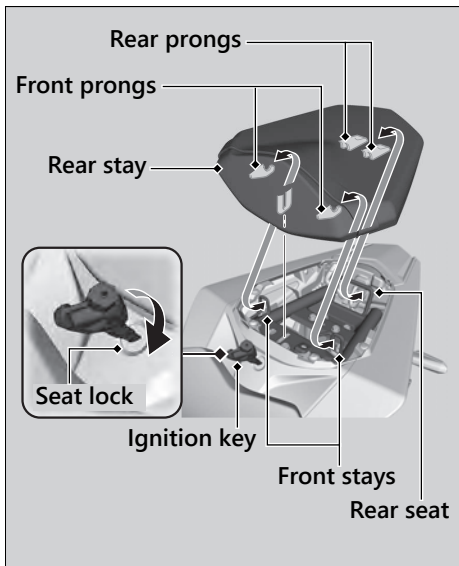

Removal

1. Insert the ignition key into the seat lock.
2. Turn it clockwise, then pull the rear seat forward and up.

Installation

1. Insert the front and rear prongs into the front and rear stays on the frame.
2. Push backward and down on the rear of the rear seat until it locks in place. Make sure that the seat is locked securely in position to pull it up lightly. The seat locks automatically when closed. Take care not to lock your key in the compartment under the rear seat.

Checking Spark Plug

For the recommended spark plug, see "Specifications." ➤ P. 107

Use only the recommended type of spark plug in the recommended heat range.

NOTICE

Using a spark plug with an improper heat range can cause engine damage.

1. Remove the right middle cowl. ➤ P. 53
2. Disconnect the spark plug cap from the spark plug.
3. Clean any dirt from around the spark plug base.
4. Remove the spark plug using the spark plug wrench provided in the tool kit.

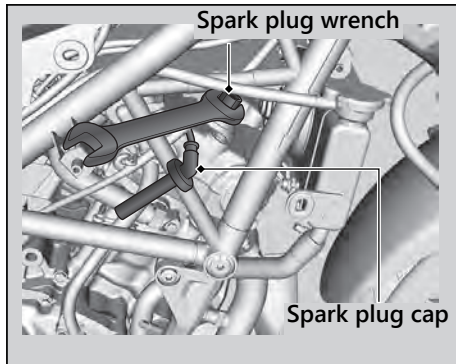

5. Inspect the electrodes and centre porcelain for deposits, erosion or carbon fouling.
 - ▶ If the erosion or deposit is heavy, replace the plug.
 - ▶ Clean a carbon or wet-fouled plug with a plug cleaner, otherwise use a wire brush.

6. Check the spark plug gap using a wire-type feeler gauge.
 - If adjustment is necessary, bend the side electrode carefully.

The gap should be:

0.8 - 0.9 mm (0.03 - 0.04 in)

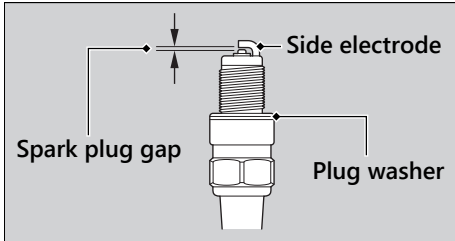

7. Make sure the plug washer is in good condition.
8. Install the spark plug. With the plug washer attached, thread the spark plug in by hand to prevent cross-threading.

9. Tighten the spark plug:
 - If the old plug is good:
 - 1/8 turn after it seats
 - If installing a new plug, tighten it twice to prevent loosening:
 - a) First, tighten the plug:
 - NGK: 1/2 turn after it seats.
 - DENSO: 3/4 turn after it seats.
 - b) Then loosen the plug.
 - c) Next, tighten the plug again:
 - 1/8 turn after it seats

NOTICE

An improperly tightened spark plug can damage the engine. If a plug is too loose, a piston may be damaged. If a plug is too tight, the threads may be damaged.

10. Reinstall the spark plug cap. Take care to avoid pinching any cables or wires.
11. Install the parts in the reverse order of removal.

Checking the Engine Oil

1. If the engine is cold, idle the engine for 3 to 5 minutes.
2. Turn the ignition switch to the OFF position and wait for 2 to 3 minutes.
3. Place your motorcycle in an upright position on a firm, level surface.
4. Remove the oil fill cap/dipstick and wipe it clean.
5. Insert the oil fill cap/dipstick until it seats, but don't screw it in.
6. Check that the oil level is between the upper level and lower level marks in the oil fill cap/dipstick.
7. Securely install the oil fill cap/dipstick.

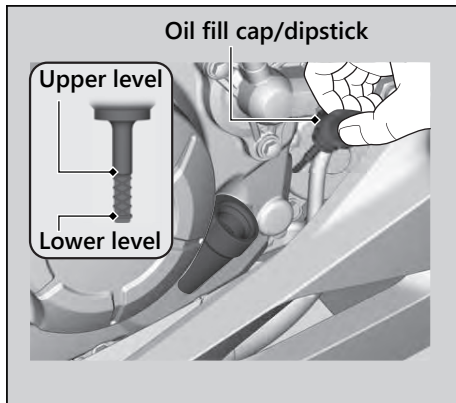

Adding Engine Oil

If the engine oil is below or near the lower level mark, add the recommended engine oil.

► P. 40, ► P. 107

1. Remove the oil fill cap/dipstick. Add the recommended oil until it reaches the upper level mark.
 - Place your motorcycle in an upright position on a firm, level surface when checking the oil level.
 - Do not overfill above the upper level mark.
 - Make sure no foreign objects enter the oil filler opening.
 - Wipe up any spills immediately.

2. Securely reinstall the oil fill cap/dipstick.

NOTICE

Overfilling with oil or operating with insufficient oil can cause damage to your engine. Do not mix different brands and grades of oil. They may affect lubrication and clutch operation.

For the recommended oil and oil selection guidelines, see "Maintenance Fundamentals."

► P. 40

Changing Engine Oil

Changing the oil requires special tools. We recommend that you have your motorcycle serviced by your dealer.

1. If the engine is cold, idle the engine for 3 to 5 minutes.
2. Turn the ignition switch to the OFF position and wait for 2 to 3 minutes.
3. Place your motorcycle on a firm, level surface.
4. Place a drain pan under the drain bolt.

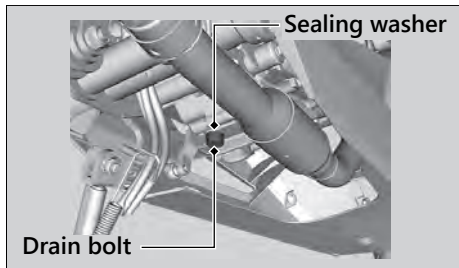

5. Remove the oil fill cap/dipstick, drain bolt and sealing washer to drain the oil.
 - Discard the oil at an approved recycling centre.
6. Install a new sealing washer onto the drain bolt. Tighten the drain bolt.

Torque: 24 N·m (2.4 kgf·m, 18 lbf·ft)

7. Fill the crankcase with the recommended oil (► P. 40, ► P. 107) and install the oil fill cap/dipstick.

Required oil

When changing oil:

1.1 L (1.2 US qt, 1.0 Imp qt)

8. Check the oil level. ► P. 58
9. Check that there are no oil leaks.

Checking the Coolant

Check the coolant level in the reserve tank while the engine is cold.

1. Place your motorcycle on a firm, level surface.
2. Hold your motorcycle in an upright position.
3. Check that the coolant level is between the UPPER level and LOWER level marks in the reserve tank.

If the coolant level is dropping noticeably or the reserve tank is empty, you likely have a serious leak. Have your motorcycle inspected by your dealer.

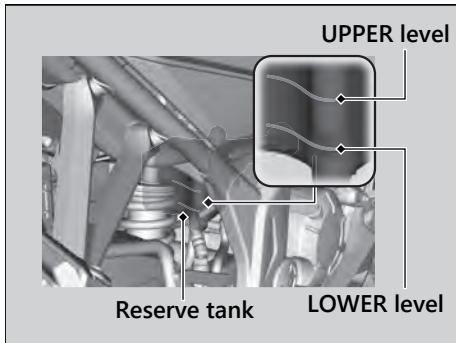

Adding Coolant

If the coolant level is below the LOWER level mark, add the recommended coolant (➤ P. 107) until the level reaches the UPPER level mark.

Add fluid only from the reserve tank cap and do not remove the radiator cap.

Coolant ► Changing Coolant

1. Remove the reserve tank cap and add fluid while monitoring the coolant level.
 - Do not overfill above the UPPER level mark.
 - Make sure no foreign objects enter the reserve tank opening.
2. Securely reinstall the reserve tank cap.

⚠ WARNING

Removing the radiator cap while the engine is hot can cause the coolant to spray out, potentially scalding you.

Always let the engine and radiator cool down before removing the radiator cap.

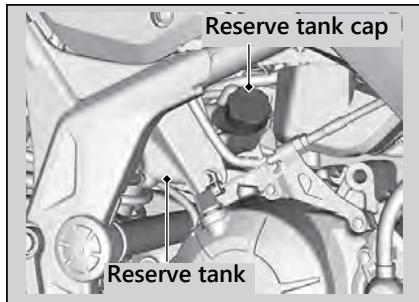

Changing Coolant

Have your dealer change the coolant unless you have the proper tools and are mechanically qualified.

Checking Brake Fluid

1. Place your motorcycle in an upright position on a firm, level surface.
2. **Front** Check that the brake fluid reservoir is horizontal and that the fluid level is above the LWR mark.
Rear Check that the brake fluid reservoir is horizontal and that the fluid level is between the LOWER level and UPPER level marks.

If the brake fluid level in either reservoir is below the LWR mark or LOWER level mark or the brake lever and pedal freeplay becomes excessive, inspect the brake pads for wear. If the brake pads are not worn, you most likely have a leak. Have your motorcycle inspected by your dealer.

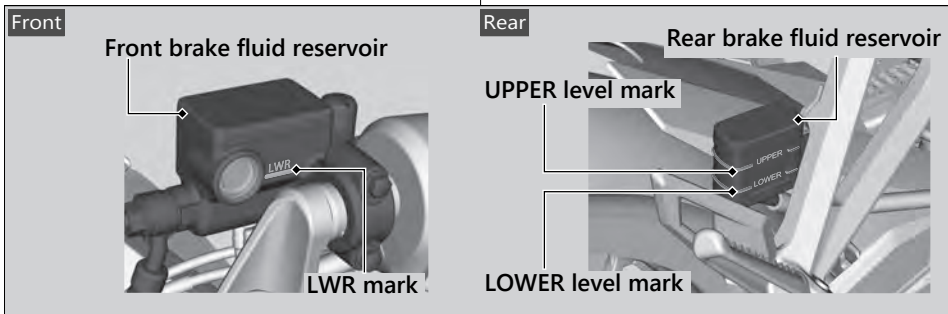

Brakes ► Inspecting the Brake Pads

Inspecting the Brake Pads

Check the condition of the brake pad wear indicators.

The pads need to be replaced if a brake pad is worn to the indicator.

1. **Front** Inspect the brake pads from below the brake caliper.
2. **Rear** Inspect the brake pads from the rear right of the motorcycle.

If necessary have the pads replaced by your dealer.

Always replace both left and right brake pads at the same time.

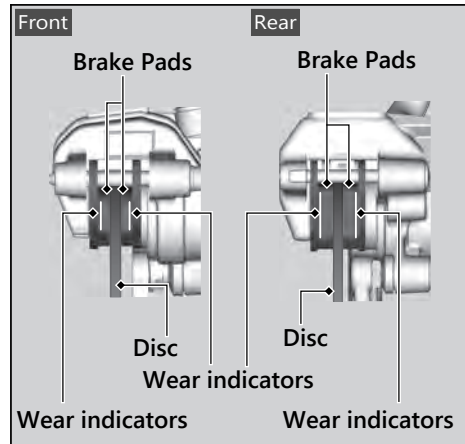

Adjusting the Brakelight Switch

Check the operation of the brakelight switch. Hold the brakelight switch and turn the adjusting nut in the direction A if the switch operates too late, or turn the nut in the direction B if the switch operates too soon.

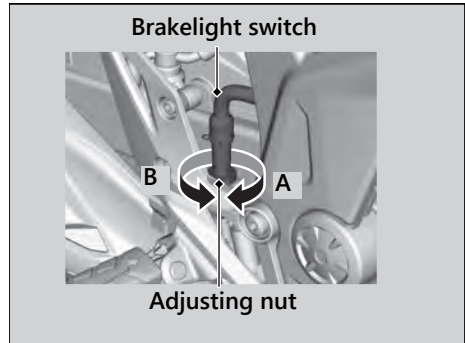

Checking the Side Stand

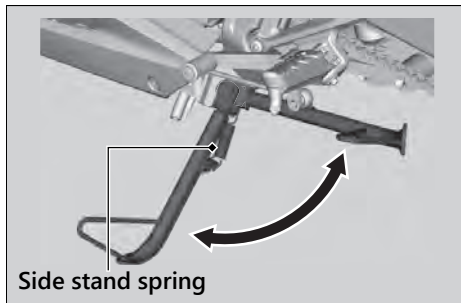

1. Check that the side stand operates smoothly. If the side stand is stiff or squeaky, clean the pivot area and lubricate the pivot bolt with clean grease.
2. Check the spring for damage or loss of tension.

Inspecting the Drive Chain Slack

Check the drive chain slack at several points along the chain. If the slack is not constant at all points, some links may be kinked and binding.

Have the chain inspected by your dealer.

1. Shift the transmission to Neutral. Stop the engine.
2. Place your motorcycle on its side stand on a firm, level surface.
3. Check the slack in the lower half of the drive chain midway between the sprockets.

Drive chain slack:

25 - 35 mm (1.0 - 1.4 in)

- ▶ Do not ride your motorcycle if the slack exceeds 50 mm (2.0 in).

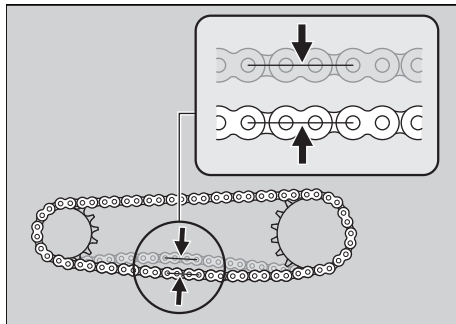

4. Roll the motorcycle forward and check that the chain moves smoothly.
5. Inspect the sprockets. ➤ P. 41
6. Clean and lubricate the drive chain. ➤ P. 42

Drive Chain ► Adjusting the Drive Chain Slack

Adjusting the Drive Chain Slack

Adjusting the chain requires special tools. Have the drive chain slack adjusted by your dealer.

1. Shift the transmission to Neutral. Stop the engine.
2. Place your motorcycle on its side stand on a firm, level surface.
3. Loosen the rear axle nut.
4. Loosen the lock nuts on both sides of the swingarm.

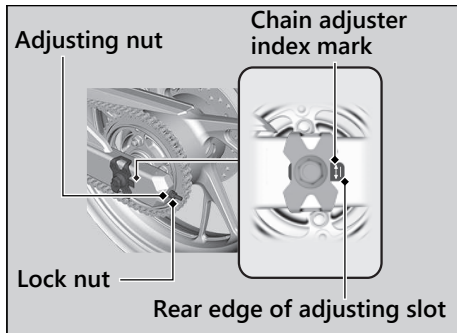
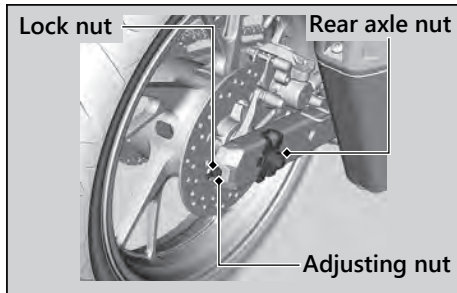

5. Turn both adjusting nuts an equal number of turns until the correct drive chain slack is obtained. Turn the adjusting nuts clockwise to tighten the chain. Turn the adjusting nuts counterclockwise to provide more slack.
Adjust the slack at a point midway between the front sprocket and the rear wheel sprocket.
Check the drive chain slack. ➤ P. 67
6. Check rear axle alignment by making sure the chain adjuster index marks align with the rear edge of the adjusting slots. Both marks should correspond. If the axle is misaligned, turn the right or left adjusting nuts until the marks are aligned and recheck chain slack.

7. Tighten the rear axle nut.

Torque: 68 N·m (6.9 kgf·m, 50 lbf·ft)

8. Tighten the drive chain adjusting nuts lightly, then hold the adjusting nuts and tighten the lock nuts.
9. Recheck drive chain slack.

If a torque wrench was not used for installation, see your dealer as soon as possible to verify proper assembly. Improper assembly may lead to loss of braking capacity.

Drive Chain ► Adjusting the Drive Chain Slack

■ Checking the Drive Chain Wear

If the drive chain slack is excessive when the rear axle is moved to the furthest limit of adjustment, the drive chain is worn and must be replaced.

Chain:

FSCM428H or KMC428HG

If necessary have the drive chain replaced by your dealer.

Checking the Clutch

Checking the Clutch Lever Freeplay

Check the clutch lever freeplay.

Freeplay at the clutch lever:

10 - 20 mm (0.4 - 0.8 in)

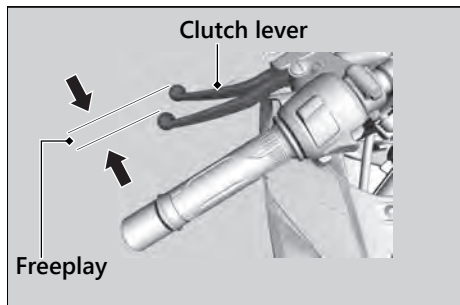

Check the clutch cable for kinks or signs of wear. If necessary have it replaced by your dealer.

Lubricate the clutch cable with a commercially available cable lubricant to prevent premature wear and corrosion.

NOTICE

Improper freeplay adjustment can cause premature clutch wear.

Clutch ► Adjusting the Clutch Lever Freeplay

Adjusting the Clutch Lever Freeplay

I Upper Adjustment

Attempt adjustment with the upper clutch cable adjuster first.

1. Pull back the rubber dust cover.
2. Loosen the upper lock nut.
3. Turn the upper clutch cable adjuster until the freeplay is 10 - 20 mm (0.4 - 0.8 in).
4. Tighten the upper lock nut and check the freeplay again.
5. Install the rubber dust cover.

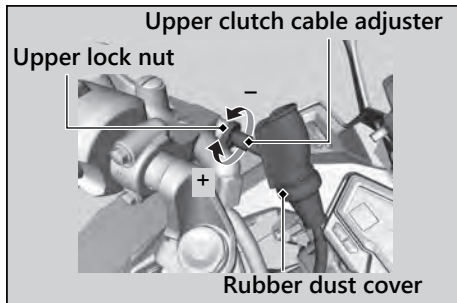

Lower Adjustment

If the upper clutch cable adjuster is threaded out near its limit, or the correct freeplay cannot be obtained, attempt adjustment with the lower clutch cable adjusting nut.

1. Loosen the upper lock nut and turn the upper clutch cable adjuster all the way in (to provide maximum freeplay). Tighten the upper lock nut.
2. Loosen the lower lock nut.
3. Turn the lower adjusting nut until the clutch lever freeplay is 10 - 20 mm (0.4 - 0.8 in).
4. Tighten the lower lock nut and check the clutch lever freeplay.
5. Start the engine, pull the clutch lever in, and shift into gear. Make sure the engine does not stall and the motorcycle does not creep. Gradually release the clutch lever and open the throttle. Your motorcycle should move smoothly and accelerate gradually.

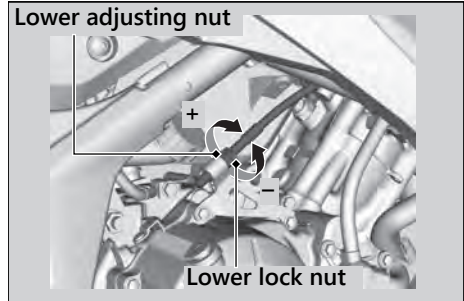

If proper adjustment cannot be obtained or the clutch does not work correctly, see your dealer.

Checking the Throttle

With the engine off, check that the throttle rotates smoothly from fully closed to fully open in all steering positions and throttle freeplay is correct. If the throttle does not move smoothly, close automatically, or if the cable is damaged, have the motorcycle inspected by your dealer.

Freeplay at the throttle grip flange:

2 - 6 mm (0.1 - 0.2 in)

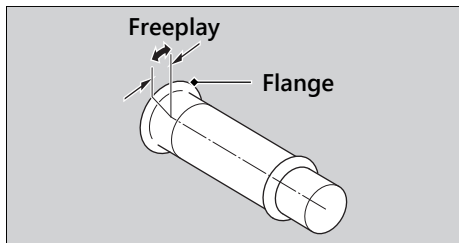

Cleaning the Crankcase Breather

1. Place a suitable container under the crankcase breather tube.
2. Remove the crankcase breather tube plug from the tube.
3. Drain deposits into a suitable container.
4. Install the crankcase breather tube plug.

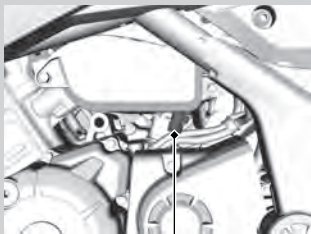

Crankcase breather tube plug

Other Adjustments

Adjusting the Headlight Aim

You can adjust vertical aim of the headlight for proper alignment. Turn the pinion in or out as necessary using a Phillips screwdriver. Obey local laws and regulations.

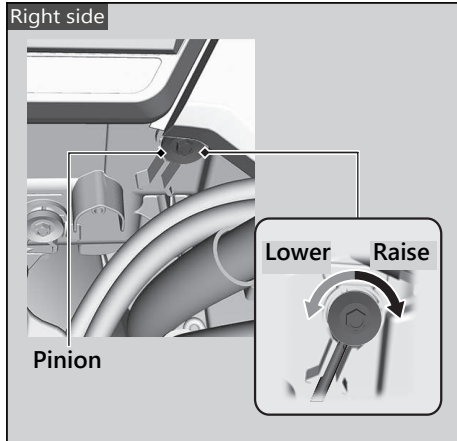
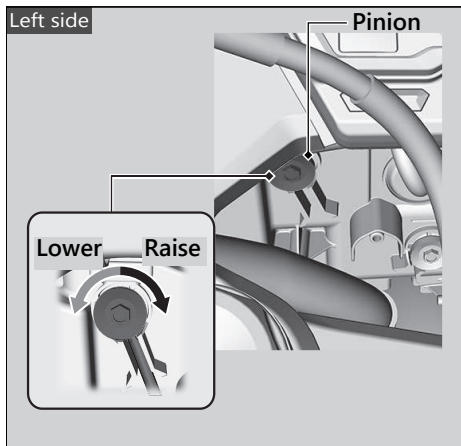

Troubleshooting

Engine Will Not Start	P. 78
Overheating (High coolant temperature indicator is on)	P. 79
Warning Indicators On or Flashing	P. 80
PGM-FI (Programmed Fuel Injection)	
Malfunction Indicator Lamp (MIL).....	P. 80
Other Warning Indications	P. 81
Fuel Gauge Failure Indication.....	P. 81
Tyre Puncture	P. 82
Electrical Trouble	P. 88
Battery Goes Dead.....	P. 88
Burned-out Light Bulb.....	P. 88
Blown Fuse.....	P. 92

Unstable Engine Operation Occurs Intermittently	P. 93
--	-------

Starter Motor Operates But Engine Does Not Start

Check the following items:

- Check the correct engine starting sequence. ➤ P. 26
- Check that there is petrol in the fuel tank.
- Check if the PGM-FI malfunction indicator lamp (MIL) is on.
 - ▶ If the indicator light is on, contact your dealer as soon as possible.

Starter Motor Does Not Operate

Check the following items:

- Check the correct engine starting sequence. ➤ P. 26
- Check for a blown fuse. ➤ P. 92
- Check for a loose battery connection or battery terminal corrosion. ➤ P. 48, ➤ P. 38
- Check the condition of the battery. ➤ P. 88

If the problem continues, have your motorcycle inspected by your dealer.

Overheating (High coolant temperature indicator is on)

The engine is overheating when the following occurs:

- High coolant temperature indicator comes on.
- Acceleration becomes sluggish.
If this occurs, pull safely to the side of the road and perform the following procedure.

Extended fast idling may cause the high coolant temperature indicator to come on.

NOTICE

Continuing to ride with an overheated engine can cause serious damage to the engine.

1. Stop the engine using the ignition switch, and then turn the ignition switch to the ON position.
2. Check that the radiator fan is operating, and then turn the ignition switch to the OFF position.
If the fan is not operating:
Suspect a fault. Do not start the engine. Transport your motorcycle to your dealer.
If the fan is operating:
Allow the engine to cool with the ignition switch in the OFF position.
3. After the engine has cooled, inspect the radiator hose and check if there is a leak.
➔ P. 61
If there is a leak:
Do not start the engine. Transport your motorcycle to your dealer.
4. Check the coolant level in the reserve tank. ➔ P. 61
▶ Add coolant as necessary.
5. If 1-4 check normal, you may continue riding, but closely monitor the high coolant temperature indicator.

PGM-FI (Programmed Fuel Injection) Malfunction Indicator Lamp (MIL)

If the indicator comes on while riding, you may have a serious problem with the PGM-FI system. Reduce speed and have your motorcycle inspected by your dealer as soon as possible.

Other Warning Indications

Fuel Gauge Failure Indication

If the fuel system has an error, the fuel gauge indicators will be displayed as shown in the illustration.

If this occurs, see your dealer as soon as possible.

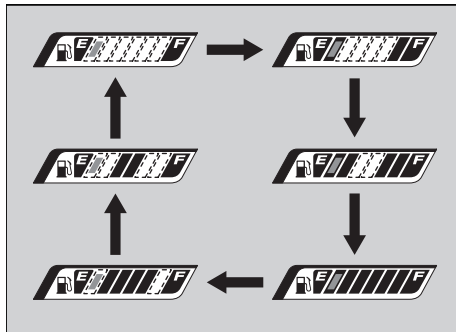
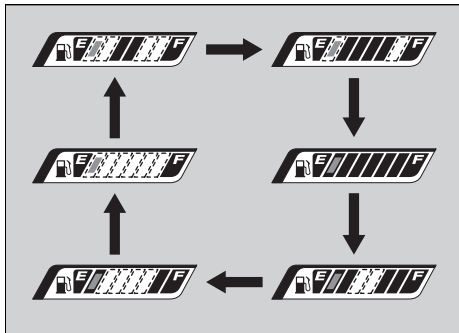

Tyre Puncture

Repairing a puncture or removing a wheel requires special tools and technical expertise. We recommend you have this type of service performed by your dealer.

After an emergency repair, always have the tyre inspected/replaced by your dealer.

Emergency Repair Using a Tyre Repair Kit

If your tyre has a minor puncture, you can make an emergency repair using a tubeless tyre repair kit.

Follow the instructions provided with the emergency tyre repair kit.

Riding your motorcycle with a temporary tyre repair is very risky. Do not exceed 50 km/h (30 mph). Have the tyre replaced by your dealer as soon as possible.

⚠️ WARNING

Riding your motorcycle with a temporary tyre repair can be risky. If the temporary repair fails, you can crash and be seriously injured or killed.

If you must ride with a temporary tyre repair, ride slowly and carefully and do not exceed 50 km/h (30 mph) until the tyre is replaced.

Removing Wheels

Follow these procedures if you need to remove a wheel in order to repair a puncture.

Front Wheel

Removal

1. Place your motorcycle on a firm, level surface.
2. Loosen the front axle nut.

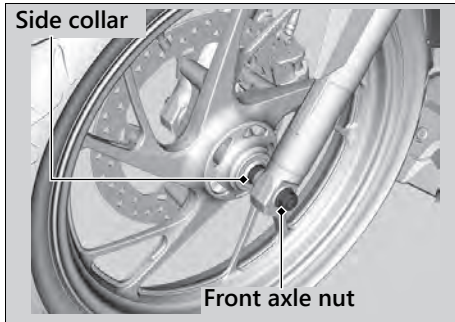

3. Support your motorcycle securely and raise the front wheel off the ground using a maintenance stand or a hoist.

4. Remove the front axle nut, front axle shaft, front wheel and side collars.
 - Avoid getting grease, oil, or dirt on the disc or pad surfaces.
 - Do not pull the brake lever while the wheel is removed.

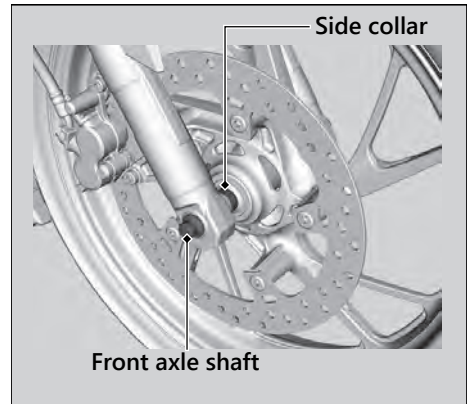

Installation

1. Attach the side collars to the front wheel.
2. Position the front wheel between the fork legs and insert the front axle shaft from the right side, through the right fork leg and wheel hub.

NOTICE

When installing the wheel, carefully fit the brake disc between the pads to avoid scratching them.

3. Tighten the axle nut.

Torque: 59 N·m (6.0 kgf·m, 44 lbf·ft)

4. After installing the wheel, apply the brake lever several times, then check if the wheel rotates freely. Recheck the wheel if the brake drags or if the wheel does not rotate freely.

If a torque wrench was not used for installation, see your dealer as soon as possible to verify proper assembly. Improper assembly may lead to loss of braking capacity.

Rear Wheel

Removal

1. Support your motorcycle securely and raise the rear wheel off the ground using a maintenance stand or a hoist.
2. Loosen the rear axle nut, lock nuts and turn the adjusting nuts so the rear wheel can be moved all the way forward for maximum drive chain slack.
3. Remove the rear axle nut.

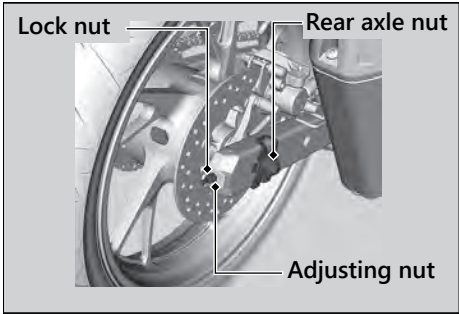

4. Remove the drive chain from the rear wheel sprocket by pushing the rear wheel forward.

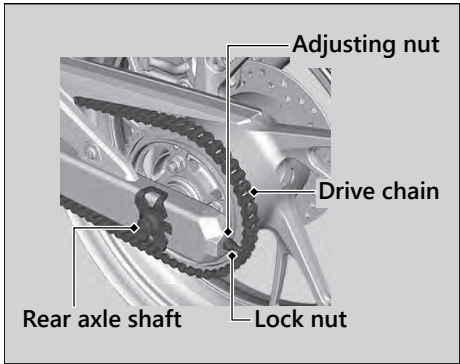

Tyre Puncture ► Removing Wheels

5. Remove the rear axle shaft, side collars and rear wheel.
 - Support the brake caliper assembly so that it doesn't hang from the brake hose. Do not twist the brake hose.
 - Avoid getting grease, oil, or dirt on the disc or pad surfaces.
 - Do not push the brake pedal while the brake caliper is removed.

Installation

1. To install the rear wheel, reverse the removal procedure.
 - Take care to prevent the brake caliper from scratching the wheel during installation.

NOTICE

When installing the brake caliper into position, carefully fit the brake disc between the pads to avoid scratching them.

2. Make sure that the slot on the brake caliper bracket is positioned in the lug on the swingarm.

Brake caliper bracket

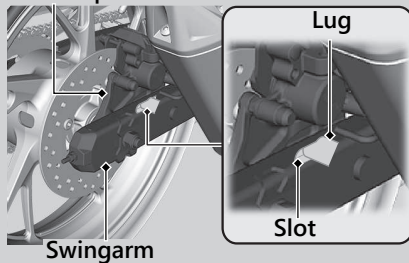

- 3. Adjust the drive chain. ➤ P. 68
- 4. Install and tighten the rear axle nut.

Torque: 68 N·m (6.9 kgf·m, 50 lbf·ft)

- 5. Tighten the drive chain adjusting nuts lightly, then hold the adjusting nuts and tighten the lock nuts.
- 6. After installing the wheel, apply the brake pedal several times, then check if the wheel rotates freely. Recheck the wheel if the brake drags or if the wheel does not rotate freely.

If a torque wrench was not used for installation, see your dealer as soon as possible to verify proper assembly. Improper assembly may lead to loss of braking capacity.

Battery Goes Dead

Charge the battery using a motorcycle battery charger.

Remove the battery from the motorcycle before charging.

Do not use an automobile-type battery charger, as these can overheat a motorcycle battery and cause permanent damage. If the battery does not recover after recharging, contact your dealer.

NOTICE

Jump starting using an automobile battery is not recommended, as this can damage your motorcycle's electrical system.

Burned-out Light Bulb

All light bulbs on the motorcycle are LEDs. If there is a LED which is not turned on, see your dealer for servicing.

| Headlight

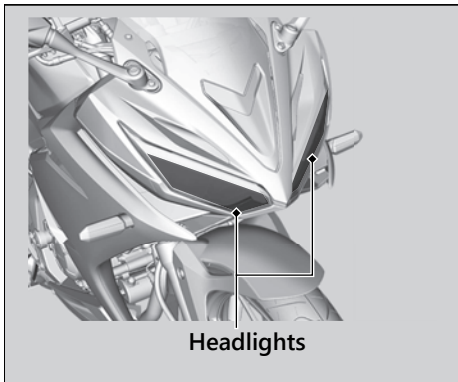

Headlights

The headlights use several LEDs. If there is a LED which is not turned on, see your dealer for servicing.

| Position Light

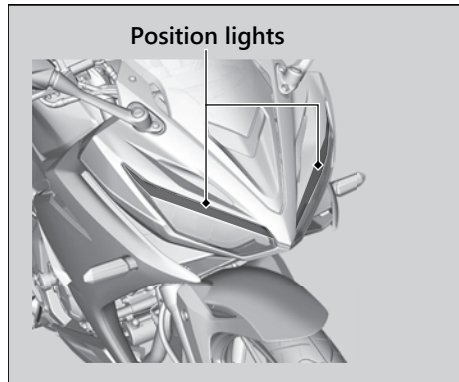

Position lights

The position lights use several LEDs. If there is a LED which is not turned on, see your dealer for servicing.

■ Brake/Tail Light

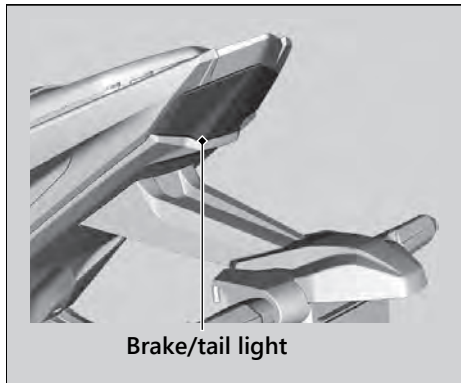

The brake and tail light uses several LEDs. If there is a LED which is not turned on, see your dealer for servicing.

■ Front/Rear Turn Signal Light

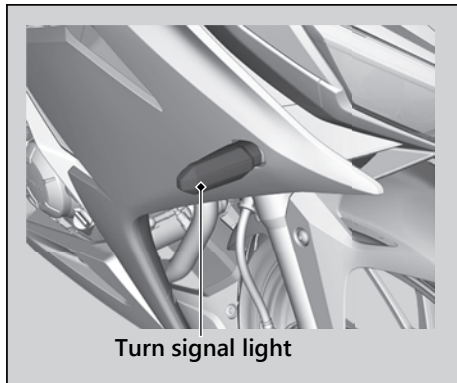

The front and rear turn signal lights use several LEDs. If there is a LED which is not turned on, see your dealer for servicing.

License Plate Light

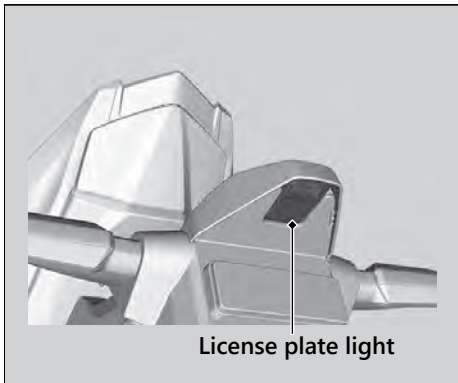

The license plate light uses several LEDs. If there is a LED which is not turned on, see your dealer for servicing.

Blown Fuse

Before handling fuses, see “Inspecting and Replacing Fuses.” ► P. 39

Fuse Box Fuses

1. Remove the front seat. ► P. 50
2. Open the fuse box cover.
3. Pull out the fuses one by one check for a blown fuse. Always replace a blown fuse with a spare fuse of the same rating.
4. Close the fuse box cover.
5. Reinstall parts in the reverse order of removal.

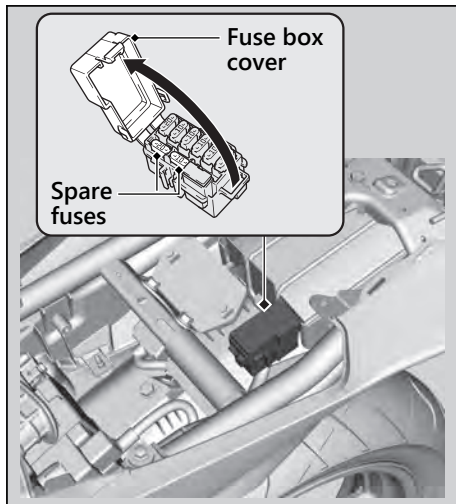

NOTICE

If a fuse fails repeatedly, you likely have an electrical problem. Have your motorcycle inspected by your dealer.

Unstable Engine Operation Occurs Intermittently

If the fuel pump filter is clogged, unstable engine operation will occur intermittently while riding.

Even if this symptom occurs, you can continue to ride your motorcycle.

If unstable engine operation occurs even if sufficient fuel is available, have your motorcycle inspected by your dealer as soon as possible.

Information

Keys.....	P. 95
Instruments, Controls, & Other Features.....	P. 96
Caring for Your Motorcycle.....	P. 97
Storing Your Motorcycle.....	P. 100
Transporting Your Motorcycle.....	P. 101
You & the Environment	P. 102
Serial Numbers	P. 103
Fuels Containing Alcohol	P. 104
Catalytic Converter	P. 105

Keys

Ignition Key

Be sure to record the key number provided with the original keys and record it in this manual.

Store the spare key in a safe location.

To make a duplicate, take the spare key or the key number to your dealer.

If you lose all keys and the key number, the ignition switch assembly will probably have to be removed by your dealer to determine the key number.

A metal key holder may cause damage to the area surrounding the ignition switch.

Instruments, Controls, & Other Features

Ignition Switch

Leaving the ignition switch in the ON position with the engine stopped will drain the battery. Do not turn the key while riding.

Odometer

The display locks at 999,999 when the read-out exceeds 999,999.

Tripmeter

The tripmeter A and B return to 0.0 when each read-out exceeds 9,999.9.

Document Bag

The owner's manual, registration, and insurance information can be stored in the plastic document bag located under the rear seat.

Ignition Cut-off System

A banking (lean angle) sensor automatically stops the engine and fuel pump if the motorcycle falls over. To reset the sensor, you must turn the ignition switch to the OFF position and back to the ON position before the engine can be restarted.

Caring for Your Motorcycle

Frequent cleaning and polishing is important to ensure the life of your Honda. A clean motorcycle makes it easier to spot potential problems.

In particular, seawater and salts used to prevent ice on roads promote the formation of corrosion. Always wash your motorcycle thoroughly after riding on coastal or treated roads.

Washing

Allow the engine, muffler, brakes, and other high-temperature parts to cool before washing.

1. Rinse your motorcycle thoroughly using a low pressure garden hose to remove loose dirt.
2. If necessary, use a sponge or a soft towel with mild cleaner to remove road grime.
 - ▶ Clean the windscreen, headlight lens, panels, and other plastic components with extra care to avoid scratching them. Avoid directing water into the air cleaner, muffler, and electrical parts.
3. Thoroughly rinse your motorcycle with plenty of clean water and dry with a soft, clean cloth.
4. After the motorcycle dries, lubricate any moving parts.
 - ▶ Make sure that no lubricant spills onto the brakes or tyres. Brake discs, pads, drum or shoes contaminated with oil will suffer greatly reduced braking effectiveness and can lead to a crash.
5. Lubricate the drive chain immediately after washing and drying the motorcycle.
6. Apply a coat of wax to prevent corrosion.
 - ▶ Avoid products that contain harsh detergents or chemical solvents. These can damage the metal, paint, and plastic on your motorcycle. Keep the wax clear of the tyres and brakes.
 - ▶ If your motorcycle has any mat painted parts, do not apply a coat of wax to the mat painted surface.

Washing Precautions

Follow these guidelines when washing:

- Do not use high-pressure washers:
 - ▶ High-pressure water cleaners can damage moving parts and electrical parts, rendering them inoperable.
 - ▶ Water in the air intake can be drawn into the throttle body and/or enter the air cleaner.
- Do not direct water at the muffler:
 - ▶ Water in the muffler can prevent starting and causes rust in the muffler.
- Dry the brakes:
 - ▶ Water adversely affects braking effectiveness. After washing, apply the brakes intermittently at low speed to help dry them.
- Do not direct water under the seat:
 - ▶ Water in the underseat compartment can damage your documents and other belongings.

- Do not direct water at the air cleaner:
 - ▶ Water in the air cleaner can prevent the engine from starting.
- Do not direct water near the headlight:
 - ▶ Any condensation inside the headlight should dissipate after a few minutes of running the engine.
- Do not use wax or polishing compounds on mat painted surface:
 - ▶ Use a soft cloth or sponge, plenty of water, and a mild detergent to clean mat painted surfaces. Dry with a soft clean cloth.

Aluminium Components

Aluminium will corrode from contact with dirt, mud, or road salt. Clean aluminium parts regularly and follow these guidelines to avoid scratches:

- Do not use stiff brushes, steel wool, or cleaners containing abrasives.
- Avoid riding over or scraping against curbs.

Panels

Follow these guidelines to prevent scratches and blemishes:

- Wash gently using a soft sponge and plenty of water.
- To remove stubborn stains, use diluted detergent and rinse thoroughly with plenty of water.
- Avoid getting petrol, brake fluid, or detergents on the instruments, panels, or headlight.

Windscreen

Using plenty of water, clean the windscreen with a soft cloth or sponge. (Avoid using detergents or any kind of chemical cleaner on the windscreen.) Dry with a soft, clean cloth.

NOTICE

To avoid possible scratching or other damage, use only water and a soft cloth or sponge to clean the windscreen.

For a dirtier windscreen, use a diluted neutral detergent with a sponge and plenty of water. Make sure to wash off all the detergent. (Detergent residue may cause windscreen cracks.)

Replace the windscreen if scratches cannot be removed and they obstruct clear vision.

Take care to keep battery electrolyte, brake fluid, or other chemical solvents off the windscreen and screen garnish. They will damage the plastic.

Exhaust Pipe and Muffler

When the exhaust pipe and muffler are painted, do not use a commercially available abrasive kitchen cleaning compound. Use a neutral detergent to clean the painted surface on the exhaust pipe and muffler. If you are not sure if your exhaust pipe and muffler are painted, contact your dealer.

Storing Your Motorcycle

If you store your motorcycle outdoors, you should consider using a full-body motorcycle cover.

If you won't be riding for an extended period, follow these guidelines:

- Wash your motorcycle and wax all painted surfaces (except mat painted surfaces). Coat chrome pieces with rust-inhibiting oil.
- Lubricate the drive chain. ➤ P. 41
- Place your motorcycle on a maintenance stand and position a block so that both tyres are off the ground.
- After rain, remove the body cover and allow the motorcycle to dry.
- Remove the battery (➤ P. 48) to prevent discharge. Charge the battery in a shaded, well-ventilated area.
 - ▶ If you leave the battery in place, disconnect the negative ⊖ terminal to prevent discharge.

After removing your motorcycle from storage, inspect all maintenance items required by the Maintenance Schedule.

Transporting Your Motorcycle

If your motorcycle needs to be transported, it should be carried on a motorcycle trailer or a flatbed truck or trailer that has a loading ramp or lifting platform, and motorcycle tie-down straps. Never try to tow your motorcycle with a wheel or wheels on the ground.

NOTICE

Towing your motorcycle can cause serious damage to the transmission.

You & the Environment

Owning and riding a motorcycle can be enjoyable, but you must do your part to protect the environment.

Choose Sensible Cleaners

Use a biodegradable detergent when you wash your motorcycle. Avoid aerosol spray cleaners that contain chlorofluorocarbons (CFCs) which damage the atmosphere's protective ozone layer.

Recycle Wastes

Put oil and other toxic wastes in approved containers and take them to a recycling centre. Call your local or state office of public works or environmental services to find a recycling centre in your area, and to get instructions on how to dispose of non-recyclable wastes. Do not place used engine oil in the trash, or pour it down a drain or on the ground. Used oil, petrol, coolant, and cleaning solvents contain poisons that can hurt refuse workers and contaminate drinking water, lakes, rivers, and oceans.

Serial Numbers

The frame and engine serial numbers uniquely identify your motorcycle and are required in order to register your motorcycle. They may also be required when ordering replacement parts.

You should record these numbers and keep them in a safe place.

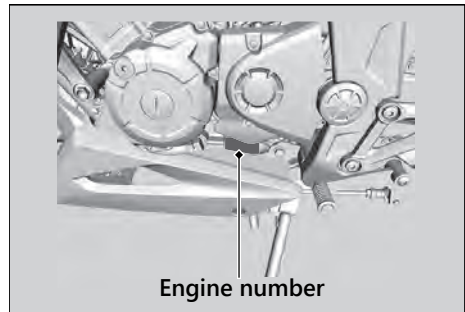
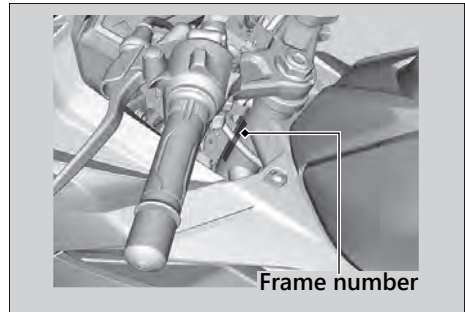

Fuels Containing Alcohol

Some conventional fuels blended with alcohol are available in some locales to help reduce emissions to meet clean air standards. If you plan to use blended fuel, check that it is unleaded and meets the minimum octane rating requirement.

The following fuel blends can be used in your motorcycle:

- Ethanol (ethyl alcohol) up to 10% by volume.
 - ▶ Petrol containing ethanol may be marketed under the name Gasohol.

The use of petrol containing more than 10% ethanol may:

- Damage the painting of the fuel tank.
- Damage the rubber tubes of the fuel line.
- Cause corrosion of the fuel tank.
- Cause poor drivability.

NOTICE

Use of blended fuels containing higher than approved percentages can damage metal, rubber, plastic parts of your fuel system.

If you notice any undesirable operating symptoms or performance problems, try a different brand of petrol.

Catalytic Converter

This motorcycle is equipped with a three-way catalytic converter. The catalytic converter contains precious metals that serve as catalysts in high temperature chemical reactions that convert hydrocarbons (HC), carbon monoxide (CO), and oxides of nitrogen (NO_x) in the exhaust gasses into safe compounds.

A defective catalytic converter contributes to air pollution and can impair your engine's performance. A replacement unit must be an original Honda part or equivalent.

Follow these guidelines to protect your motorcycle's catalytic converter.

- Always use unleaded petrol. Leaded petrol will damage the catalytic converter.
- Keep the engine in good running condition.
- Have your motorcycle serviced if your engine is misfiring, backfiring, stalling, or otherwise not running properly, stop riding and turn off the engine.

Specifications

■ Main Components

Overall length	1,983 mm (78.1 in)
Overall width	694 mm (27.3 in)
Overall height	1,039 mm (40.9 in)
Wheelbase	1,309 mm (51.5 in)
Minimum ground clearance	166 mm (6.5 in)
Caster angle	25°
Trail	91 mm (3.6 in)
Curb weight	135 kg (298 lb)
Maximum weight capacity *1	130 kg (287 lb)
Passenger capacity	Rider and 1 passenger
Minimum turning radius	2.5 m (8.20 ft)

*1 : Including rider, passenger, all luggage, and accessories

Displacement	149 cm ³ (9.1 cu-in)	
Bore x stroke	57.300 x 57.843 mm (2.2559 x 2.2773 in)	
Compression ratio	11.3 : 1	
Fuel	Unleaded petrol Recommended: 88 RON or higher	
Tank capacity	12.0 L (3.17 US gal, 2.64 Imp gal)	
Battery	GTZ6V 12V-5.0Ah (10 HR)	
Gear ratios	1st	3.083
	2nd	1.941
	3rd	1.500
	4th	1.227
	5th	1.041
	6th	0.923
Reduction ratios (primary / final)	3.260 / 3.000	

■ Service Data

Tyre size	Front	100/80-17M/C 52P
	Rear	130/70-17M/C 62P
Tyre type	Bias-ply, tubeless	
Recommended Tyres	Front	IRC RX-01F
	Rear	IRC RX-01R
Tyre air pressure (Driver only)	Front	175 kPa (1.75 kgf/cm ² , 25 psi)
	Rear	200 kPa (2.00 kgf/cm ² , 29 psi)
Tyre air pressure (Driver and passenger)	Front	175 kPa (1.75 kgf/cm ² , 25 psi)
	Rear	225 kPa (2.25 kgf/cm ² , 33 psi)
Minimum tread depth	Front	1.5 mm (0.06 in)
	Rear	2.0 mm (0.08 in)
Spark plugs	MR9C-9N (NGK) or U27EPR-N9 (DENSO)	
Spark plug gap	0.8 - 0.9 mm (0.03 - 0.04 in)	
Idle speed	1,600 ± 100 rpm	
Recommended engine oil	Honda 4-stroke motorcycle oil API Service Classification SG or higher, excluding oils marked as "Energy Conserving" or "Resource Conserving," SAE 10W-30, JASO T 903 standard MA	
Engine oil capacity	After draining	1.1 L (1.2 US qt, 1.0 Imp qt)
	After disassembly	1.3 L (1.4 US qt, 1.1 Imp qt)

Recommended brake fluid	Honda DOT 3 or DOT 4 Brake Fluid	
Cooling system capacity	0.58 L (0.61 US qt, 0.51 Imp qt)	
Recommended coolant	HONDA PRE-MIX COOLANT	
Recommended drive chain lubricant	Drive chain lubricant. If not available, use SAE 80 or 90 gear oil.	
Drive chain slack	25 - 35 mm (1.0 - 1.4 in)	
Standard drive chain	FSCM428H or KMC428HG	
	No. of links	128
Standard sprocket sizes	Drive sprocket	15T
	Driven sprocket	45T

Specifications

■ Bulbs

Headlights	LED
Brake/Tail light	LED
Front turn signal lights	LED
Rear turn signal lights	LED
Position lights	LED
License plate light	LED

■ Fuses

Main fuse	20A
Other fuses	10A

■ Torque Specifications

Seat lock cover bolts	4.2 N·m (0.4 kgf·m, 3.1 lbf·ft)
Right middle cowl bolts B	4.2 N·m (0.4 kgf·m, 3.1 lbf·ft)
Engine oil drain bolt	24 N·m (2.4 kgf·m, 18 lbf·ft)
Rear axle nut	68 N·m (6.9 kgf·m, 50 lbf·ft)
Front axle nut	59 N·m (6.0 kgf·m, 44 lbf·ft)

A

Accessories	10
Air Cleaner	46
Average Fuel Mileage	17

B

Battery	38, 48
Brake/Tail Light	90
Brakelight Switch	65

Brakes

Fluid	41, 63, 107
Pad Wear	64

Braking	7
---------------	---

Bulb

Brake/Tail Light	90
Front/Rear Turn Signal Light	90
Headlight	89
License Plate Light	91
Position Light	89

C

Caring for Your Motorcycle	97
Clip	49
Clock	15, 19

Clutch

Fluid	107
Freeplay	72

Clutch System	71
---------------------	----

Coolant	42, 61
---------------	--------

Crankcase Breather	75
--------------------------	----

Crash	5
-------------	---

Current Fuel Mileage	17
----------------------------	----

D

Digital Clock Adjustment	19
--------------------------------	----

Document Bag	30, 96
--------------------	--------

Drive Chain	41, 67
-------------------	--------

E

Electrical Trouble	88
--------------------------	----

Engine

Number	103
Oil	40, 58
Overheats	79
Starting	26
Will Not Start	78

Environment	102
-------------------	-----

Equipment

Owner's Manual	30, 96
Tool Kit.....	30

F

Flooded Engine	26
Frame Number	103
Front Seat	50
Front/Rear Turn Signal Light	90

Fuel

Gauge	15
Recommended	29
Remaining	15
Tank Capacity	29

Fuels Containing Alcohol.....	104
-------------------------------	-----

Fuses	39, 92
-------------	--------

G

Gasohol	104
Gear Position Indicator	15

H

Harness Band Clip	52
Headlight	89

Headlight Aim	76
---------------------	----

Headlight Dimmer Switch	22
-------------------------------	----

Helmet Holder	30
---------------------	----

High Beam Indicator	21
---------------------------	----

High Coolant Temperature Indicator ...	20, 79
--	--------

Horn Button	22
-------------------	----

I**Ignition Cut-off System**

Banking Sensor	96
----------------------	----

Ignition Key.....	95
-------------------	----

Ignition Switch.....	23, 26, 96
----------------------	------------

Indicators	20
------------------	----

Instruments	14
-------------------	----

Instruments, Controls, & Other Features ...	96
---	----

K

Keys.....	95
-----------	----

L

License Plate Light.....	91
--------------------------	----

Load Limits	11
-------------------	----

Loading Guidelines.....	11
-------------------------	----

M

Maintenance

Fundamentals	36
Importance	32
Safety	32
Schedule.....	33

Maximum Weight Limit	11
-----------------------------------	----

Modifications	10
----------------------------	----

N

Neutral Indicator	21
--------------------------------	----

O

Odometer	17, 96
-----------------------	--------

Oil

Engine	40, 58
--------------	--------

Overheating	79
--------------------------	----

P

Parking	9
----------------------	---

Parts Location	12
-----------------------------	----

Passing Light Control Switch	22
---	----

Petrol	29
---------------------	----

PGM-FI (Programmed Fuel Injection)

Malfunction Indicator Lamp (MIL)	20, 80
---	--------

Position Light	89
-----------------------------	----

Protective Apparel	6
---------------------------------	---

R

Rear Seat	55
------------------------	----

Recommended

Coolant	42
---------------	----

Engine Oil.....	40, 58
-----------------	--------

Fuel	29
------------	----

Oil	40
-----------	----

Refuelling	29
-------------------------	----

Removal

Battery.....	48
--------------	----

Clip.....	49
-----------	----

Front Seat.....	50
-----------------	----

Harness Band Clip.....	52
------------------------	----

Rear Seat.....	55
----------------	----

Right Middle Cowl	53
-------------------------	----

Repair Kit	82
-------------------------	----

Riding Precautions	7
---------------------------------	---

Right Middle Cowl	53
--------------------------------	----

S	
Safety Guidelines	3
Safety Precautions	6
SEL button	14
Serial Numbers.....	103
SET button.....	14
Shifting Gears	28
Shutter.....	25
Side Stand.....	66
Spark Plugs.....	56
Specifications.....	106
Speedometer	15
Start Button.....	22
Starting the Engine	26
Steering Lock	24
Storage	
Compartment	30
Equipment	30
Owner's Manual	30, 96
Storing	100
Switches	22
T	
Tachometer	14
Throttle.....	74
Tool Kit.....	30
Transporting	101
Tripmeter.....	17, 96
Troubleshooting	77
Turn Signal Indicator	21
Turn Signal Switch.....	22
Tyres	
Air Pressure	43
Puncture.....	82
Replacing.....	43, 82
W	
Warning Indicators On.....	80
Washing	97
Weight Limit.....	11, 106
Wheels	
Front Removal	83
Rear Removal.....	85

HONDA

The Power of Dreams

For Comments and Suggestions you may contact us at:

Honda Philippines, Inc.

Head Office & Manufacturing Plant

Lot 34 Phase 1 - B Road 3,

First Philippine Industrial Park,

Tanauan City 4234 Batangas

Tel. Nos. (632) 581-6700 to 99

Tel. Nos. (632) 756-7300 to 59

Email : customerservice@hondaph.com

Website: www.hondaph.com

32K45B000HPI-EP

PRINTED IN THE PHILIPPINES