

HONDA

OWNER'S MANUAL

**2018
CB1100NA**



This manual should be considered a permanent part of the motorcycle and should remain with the motorcycle when it is resold.

This publication includes the latest production information available before printing. Honda Motor Co., Ltd. reserves the right to make changes at any time without notice and without incurring any obligation.

No part of this publication may be reproduced without written permission.

The vehicle pictured in this owner's manual may not match your actual vehicle.

Welcome

Congratulations on your purchase of a new Honda motorcycle. Your selection of a Honda makes you part of a worldwide family of satisfied customers who appreciate Honda's reputation for building quality into every product.

To ensure your safety and riding pleasure:

- Read this owner's manual carefully.
- Follow all recommendations and procedures contained in this manual.
- Pay close attention to safety messages contained in this manual and on the motorcycle.

To protect your investment, we urge you to take responsibility for keeping your motorcycle well serviced and maintained. Also, observe the break-in guidelines, and always perform the pre-ride inspection and other periodic checks in this manual.

When service is required, remember that your Honda dealer knows your motorcycle best. If you have the required mechanical "know-how" and tools, you can purchase an official Honda Service Manual to help you perform many maintenance and repair tasks.

➤ P. 120

Read the warranty information thoroughly so that you understand the warranty coverage and that you are aware of your rights and responsibilities. ➤ P. 121

You may also want to visit our website at www.honda.ca.

Happy riding!

A Few Words About Safety

Your safety, and the safety of others, is very important. Operating this motorcycle safely is an important responsibility.

To help you make informed decisions about safety, we have provided operating procedures and other information on safety labels and in this manual. This information alerts you to potential hazards that could hurt you or others.

Of course, it is not practical or possible to warn you about all hazards associated with operating or maintaining a motorcycle. You must use your own good judgment.

You will find important safety information in a variety of forms, including:

- Safety labels on the motorcycle
- Safety Messages preceded by a safety alert symbol  and one of three signal words: DANGER, WARNING, or CAUTION.

These signal words mean:

DANGER

You **WILL** be **KILLED** or **SERIOUSLY HURT** if you don't follow instructions.

WARNING

You **CAN** be **KILLED** or **SERIOUSLY HURT** if you don't follow instructions.

CAUTION

You **CAN** be **HURT** if you don't follow instructions.

Other important information is provided under the following titles:

NOTICE Information to help you avoid damage to your motorcycle, other property, or the environment.

Contents

Motorcycle Safety P. 2

Operation Guide P. 16

Maintenance P. 39

Troubleshooting P. 84

Information P. 103

Specifications P. 124

Index P. 128

Motorcycle Safety

This section contains important information for safe riding of your motorcycle.
Please read this section carefully.

Safety Guidelines	P. 3
Safety Labels	P. 7
Safety Precautions	P. 8
Riding Precautions	P. 9
Accessories & Modifications	P. 13
Loading	P. 14

Safety Guidelines

Follow these guidelines to enhance your safety:

- Perform all routine and regular inspections specified in this manual.
- Stop the engine and keep sparks and flame away before filling the fuel tank.
- Do not run the engine in enclosed or partly enclosed areas. Carbon monoxide in exhaust gases is toxic and can kill you.

Always Wear a Helmet

It's a proven fact: helmets and protective apparel significantly reduce the number and severity of head and other injuries. So always wear an approved motorcycle helmet and protective apparel. ➔ P. 8

Before Riding

Make sure that you are physically fit, mentally focused and free of alcohol and drugs. Check that you and your passenger are both wearing an approved motorcycle helmet and protective apparel. Instruct your passenger on holding onto the grab rail or your waist, leaning with you in turns, and keeping their feet on the footpegs, even when the motorcycle is stopped.

Take Time to Learn & Practice

Even if you have ridden other motorcycles, practice riding in a safe area to become familiar with how this motorcycle works and handles, and to become accustomed to the motorcycle's size and weight.

We recommend that all riders take a certified rider training course. New riders should always start with a basic course, and even experienced riders will find an advanced course beneficial. The Motorcycle and Moped Industry Council (MMIC) offers information about rider training on their website (www.mmic.ca). For local information and requirements, or to find a list of approved training providers, riders should check with their provincial transportation authority.

Ride Defensively

Always pay attention to other vehicles around you, and do not assume that other drivers see you. Be prepared to stop quickly or perform an evasive maneuver.

Make Yourself Easy to See

Make yourself more visible, especially at night, by wearing bright reflective clothing, positioning yourself so other drivers can see you, signaling before turning or changing lanes, and using your horn when necessary.

Ride within Your Limits

Never ride beyond your personal abilities or faster than conditions warrant. Fatigue and inattention can impair your ability to use good judgment and ride safely.

Don't Drink and Ride

Alcohol and riding don't mix. Even one alcoholic drink can reduce your ability to respond to changing conditions, and your reaction time gets worse with every additional drink. Don't drink and ride, and don't let your friends drink and ride either.

Keep Your Honda in Safe Condition

It's important to keep your motorcycle properly maintained and in safe riding condition. Inspect your motorcycle before every ride and perform all recommended maintenance. Never exceed load limits (▶ P. 14), and do not modify your motorcycle or install accessories that would make your motorcycle unsafe (▶ P. 13).

If You are Involved in a Crash

Personal safety is your first priority. If you or anyone else has been injured, take time to assess the severity of the injuries and whether it is safe to continue riding. Call for emergency assistance if needed. Also follow applicable laws and regulations if another person or vehicle is involved in the crash.

If you decide to continue riding, first turn the ignition switch to the OFF position, and evaluate the condition of your motorcycle. Inspect for fluid leaks, check the tightness of critical nuts and bolts, and check the handlebar, control levers, brakes, and wheels. Ride slowly and cautiously.

Your motorcycle may have suffered damage that is not immediately apparent. Have your motorcycle thoroughly checked at a qualified service facility as soon as possible.

Carbon Monoxide Hazard

Exhaust contains poisonous carbon monoxide, a colorless, odorless gas. Breathing carbon monoxide can cause loss of consciousness and may lead to death.

If you run the engine in confined or even partly enclosed area, the air you breathe could contain a dangerous amount of carbon monoxide.

Never run your motorcycle inside a garage or other enclosure.

WARNING

Running the engine of your motorcycle while in an enclosed or even partially enclosed area can cause a rapid build-up of toxic carbon monoxide gas.

Breathing this colorless, odorless gas can quickly cause unconsciousness and lead to death.

Only run your motorcycle's engine when it is located in a well ventilated area outdoors.

Safety Labels

Safety and information labels on your motorcycle provide important safety information and may warn you of potential hazards that could cause serious injury. Read these labels carefully and don't remove them.

If a label comes off or becomes hard to read, contact your dealer for a replacement.

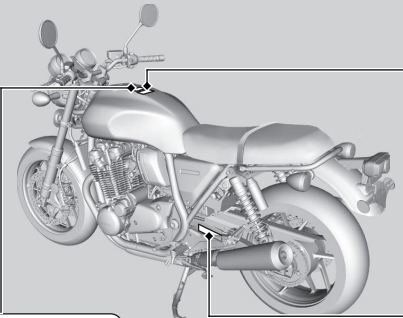

For your protection, always wear your helmet while riding. Read the owner's manual carefully.

⚠ WARNING

Improper loading can cause a crash and you may be seriously hurt or killed. See "Load Limits and Guidelines" in your Owner's Manual for complete instructions.

TIRE INFORMATION

Cold tire pressures		kPa	kgf/cm ²	psi
Up to maximum weight capacity	Front	250	2.5	36
	Rear	200	2.0	29
Up to 90kg(200lbs) load	Front	200	2.0	29
	Rear	250	2.5	36
Tire size	Front	160/80R17 (4.85/17)		
	Rear	180/80R17 (4.85/17)		
Min. recommend tire center tread depth	Front	1.6mm (0.06in.)		
	Rear	2.0mm (0.08in.)		
Maximum weight capacity		159kg(351lbs)		

DRIVE CHAIN

Keep chain adjusted and lubricated 30 mm (1 1/4 in.) Freesley



Read owner's manual.

Safety Precautions

- Ride cautiously and keep your hands on the handlebar and feet on the footpegs.
- Keep passenger's hands onto the grab rail or your waist, passenger's feet on the footpegs while riding.
- Always consider the safety of your passenger, as well as other drivers and riders.

Protective Apparel

Make sure that you and any passenger are wearing an approved motorcycle helmet, eye protection, and high-visibility protective clothing. Ride defensively in response to weather and road conditions.

■ Helmet

Should be safety-standard certified, high-visibility, and correct size for your head

- Must fit comfortably but securely, with the chin strap fastened.
- Face shield with unobstructed field of vision or other approved eye protection

WARNING

Not wearing a helmet increases the chance of serious injury or death in a crash.

Make sure that you and any passenger always wear an approved helmet and protective apparel.

I Gloves

Full-finger leather gloves with high abrasion resistance

I Boots or Riding Shoes

Sturdy boots with non-slip soles and ankle protection

I Jacket and Pants

Protective, highly visible, long-sleeved jacket and durable long pants for riding (or a protective suit)

Riding Precautions

Break-in Period

During the first 500 km (300 miles) of running, follow these guidelines to ensure your motorcycle's future reliability and performance.

- Avoid full-throttle starts and rapid acceleration.
- Avoid hard braking and rapid down-shifts.
- Ride conservatively.

Brakes

Observe the following guidelines:

- Avoid excessively hard braking and downshifting.
 - ▶ Sudden braking can reduce the motorcycle's stability.
 - ▶ Where possible, reduce speed before turning; otherwise you risk sliding out.
- Exercise caution on low traction surfaces.
 - ▶ The tires slip more easily on such surfaces and braking distances are longer.
- Avoid continuous braking.
 - ▶ Repeated braking, such as when descending long, steep slopes can seriously overheat the brakes, reducing their effectiveness. Use engine braking with intermittent use of the brakes to reduce speed.
- For full braking effectiveness, operate both the front and rear brakes together.

Anti-lock Brake System (ABS)

This model is equipped with an Anti-lock Brake System (ABS) designed to help prevent the brakes from locking up during hard braking.

- ABS does not reduce braking distance. In certain circumstances, ABS may result in a longer stopping distance.
- ABS does not function at speeds below 10 km/h (6 mph).
- The brake lever and pedal may recoil slightly when applying the brakes. This is normal.
- Always use the recommended front/rear tires and sprockets to ensure correct ABS operation.

■ Engine Braking

Engine braking helps slow your motorcycle down when you release the throttle. For further slowing action, downshift to a lower gear. Use engine braking with intermittent use of the brakes to reduce speed when descending long, steep slopes.

■ Wet or Rainy Conditions

Road surfaces are slippery when wet, and wet brakes further reduce braking efficiency. Exercise extra caution when braking in wet conditions.

If the brakes get wet, apply the brakes while riding at low speed to help them dry.

Parking

- Park on a firm, level surface.
- If you must park on a slight incline or loose surface, park so that the motorcycle cannot move or fall over.
- Make sure that high-temperature parts cannot come into contact with flammable materials.
- Do not touch the engine, muffler, brakes and other high-temperature parts until they cool down.
- To reduce the likelihood of theft, always lock the handlebar and remove the key when leaving the motorcycle unattended. Use of an anti-theft device is also recommended.

Parking with the Side Stand or Center Stand

1. Stop the engine.
2. **Using the side stand**
Push the side stand down.
Slowly lean the motorcycle to the left until its weight rests on the side stand.

Using the center stand

To lower the center stand, stand on the left side of the motorcycle. Hold the left handle grip and the left grab rail. Press down on the tip of the center stand with your right foot and, simultaneously, pull up and back.

3. Turn the handlebar fully to the left.
▶ Turning the handlebar to the right reduces stability and may cause the motorcycle to fall.
4. Turn the ignition switch to the LOCK position and remove the key. ➤ P. 32

Refueling and Fuel Guidelines

Follow these guidelines to protect the engine, fuel system and catalytic converter:

- Use only unleaded gasoline.
- Use recommended octane number. Using lower octane gasoline will result in decreased engine performance.
- Do not use fuels containing a high concentration of alcohol. ➤ P. 119
- Do not use stale or contaminated gasoline or an oil/gasoline mixture.
- Avoid getting dirt or water in the fuel tank.

Accessories & Modifications

We strongly advise that you do not add any accessories that were not specifically designed or approved for your motorcycle by Honda or make modifications to your motorcycle from its original design. Doing so can make it unsafe. Modifying your motorcycle may also void your warranty and make your motorcycle illegal to operate on public roads and highways. Before deciding to install accessories on your motorcycle be certain the modification is safe and legal.

⚠️ WARNING

Improper accessories or modifications can cause a crash in which you can be seriously hurt or killed.

Follow all instructions in this owner's manual regarding accessories and modifications.

Do not pull a trailer with, or attach a sidecar to, your motorcycle. Your motorcycle was not designed for these attachments, and their use can seriously impair your motorcycle's handling.

Loading

- Carrying extra weight affects your motorcycle's handling, braking and stability. Always ride at a safe speed for the load you are carrying.
- Avoid carrying an excessive load and keep within specified load limits.
Maximum weight capacity ➤ P. 124
- Tie all luggage securely, evenly balanced and close to the center of the motorcycle.
- Do not place objects near the lights or the muffler.

WARNING

Overloading or improper loading can cause a crash and you can be seriously hurt or killed.

Follow all load limits and other loading guidelines in this manual.

Parts Location

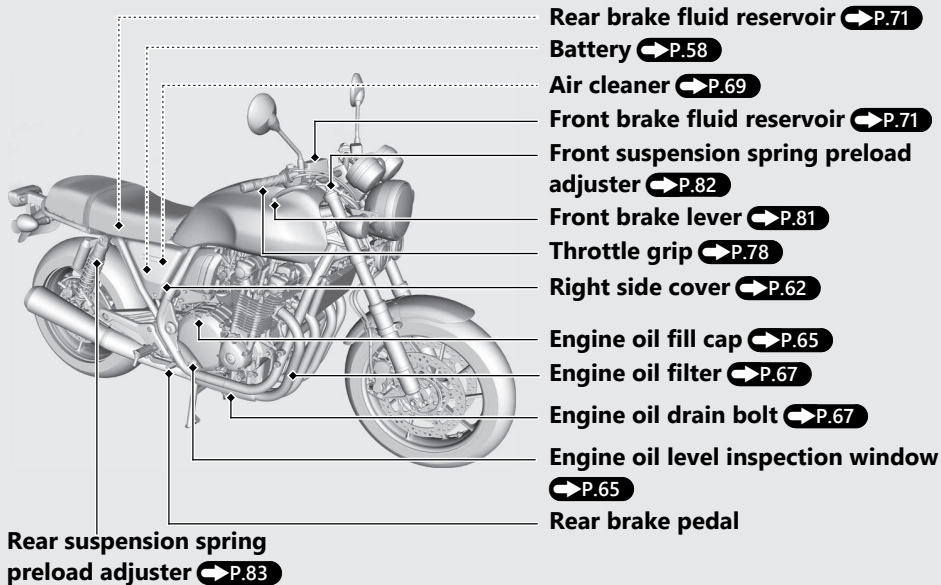

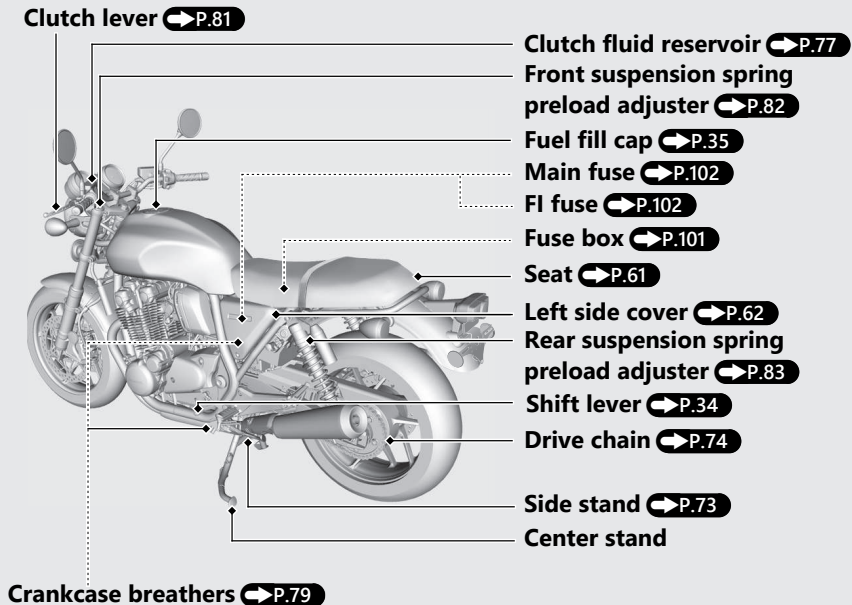

Instruments

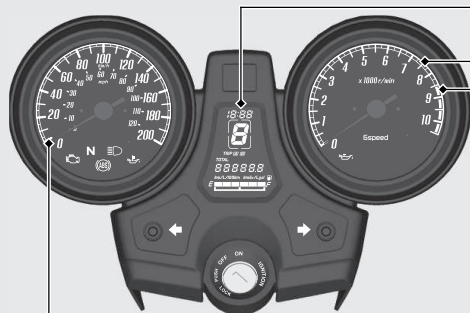

Speedometer

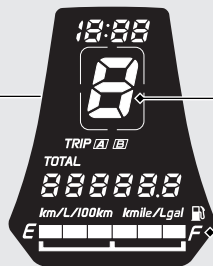

Tachometer

NOTICE

Do not operate the engine in the tachometer red zone. Excessive engine speed can adversely affect engine life.

Tachometer red zone
(excessive engine rpm range)

Gear position indicator

The gear position is shown in the gear position indicator.

▶ "-" flashes when the transmission is not shifted properly.

Fuel gauge

Remaining fuel when only 1st (E) segment starts flashing approximately: 3.6 L (0.9 US gal, 0.79 Imp gal)

At the same time, the available driving distance and remaining fuel displays can be selected. **➡P.23**



If the fuel gauge indicator flashes in a repeat pattern or turns off: **➡P.89**

Display Check

When the ignition switch is turned to the ON position, all the modes and digital segments will show. If any part of these displays does not come on when it should, have your dealer check for problems.

Instruments *(Continued)*

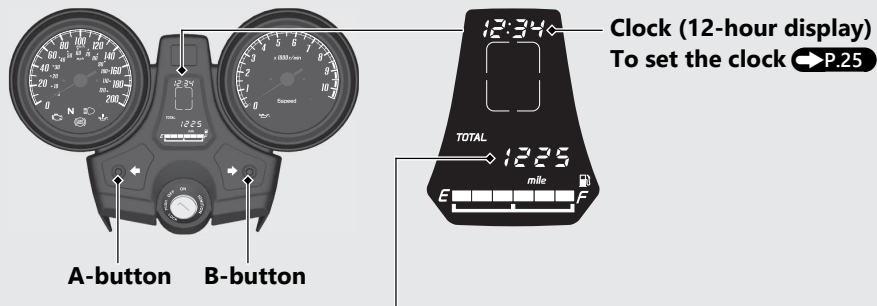

Odometer [TOTAL] & Tripmeter [TRIP A/B] & Fuel mileage meter & Fuel consumption meter

A-button selects the odometer, tripmeter A, tripmeter A average fuel mileage, tripmeter A fuel consumption, tripmeter B, tripmeter B average fuel mileage, tripmeter B fuel consumption and current fuel mileage.

- Odometer: Total distance ridden.
- Tripmeter: Distance ridden since tripmeter was reset (Press and hold A-button to reset to 0.0 km. At the same time it will reset the average fuel mileage and fuel consumption).

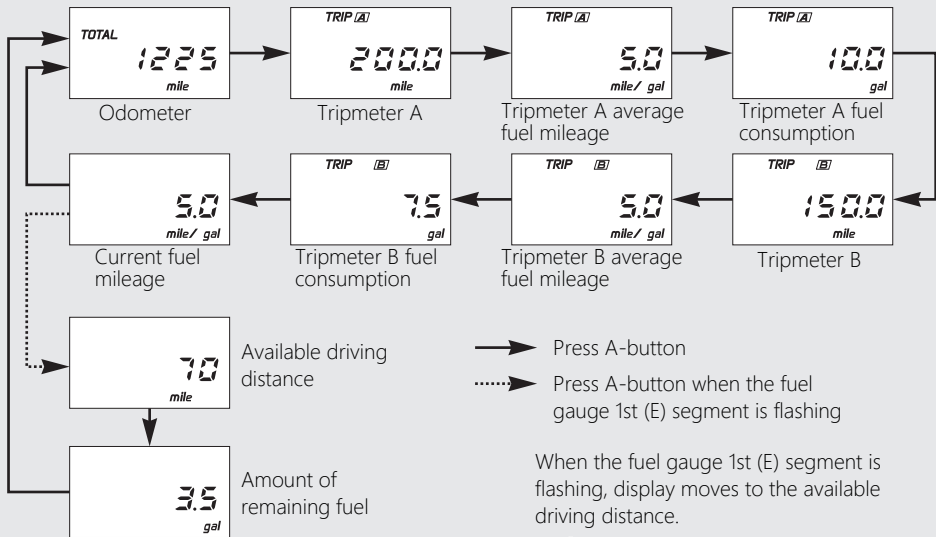

When the fuel gauge 1st (E) segment is flashing, display moves to the available driving distance.



Instruments *(Continued)*

The average fuel mileage and fuel consumption will be based on each tripmeter A and tripmeter B.

Average fuel mileage

Average fuel mileage since each tripmeter A and tripmeter B was reset. It display "--.-" after resetting each tripmeter A and tripmeter B.

When "--.-" is displayed in other cases, go to your dealer for service.

Fuel consumption

Total fuel consumption since each tripmeter A and tripmeter B was reset. When "---.-" is displayed, go to your dealer for service.

To reset the average fuel mileage and fuel consumption:  **P.20**

Current fuel mileage

Current instant mileage. If your speed is less than 7 km/h (4 mph) or immediately after ignition switch is turned to ON, "--.-" is displayed.

When "--.-" is displayed at speeds above 7 km/h (4 mph), go to your dealer for service.

Available driving distance

When the 1st (E) segment of the fuel gauge is flashing  , the estimated available driving distance can be selected. When the amount of remaining fuel becomes less than 1.0 L (0.26 US gal), "--" will be indicated. The indicated available driving distance is by calculation depending on the driving conditions, and the indicated figure may not always be the actual allowable distance. When the fuel gauge is near to E or when E segment blinks, fill fuel promptly.

Remaining fuel

When the 1st (E) segment of the fuel gauge is flashing  , the estimated amount of remaining fuel can be selected. When the amount of remaining fuel becomes less than 1.0 L (0.26 US gal), "--" will be indicated. The amount of remaining fuel is calculated from the driving conditions. The indicated amount of remaining fuel may be different from the actual amount. When the fuel gauge is near to E or when E segment blinks, fill fuel promptly.

Instruments *(Continued)*

Display Setting

You can adjust the display settings.

- Clock setting
- Changing of mileage units
- Changing of fuel mileage units

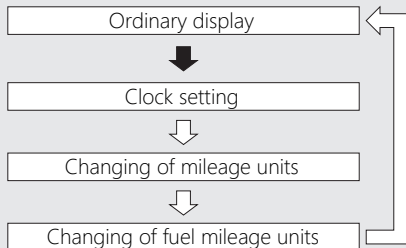

➡ Press and hold A-button and B-button

⇨ Press B-button

In addition, to return to the ordinary display at display setting, turn the ignition switch to the OFF position and then ON position, adjustment will be set.

Adjustment will be cancelled if the button is not pressed for about 30 seconds, unless each display setting was pre-set individually.

Clock setting:

- 1 Turn the ignition switch to the ON position.
- 2 Press and hold A-button and B-button until the hour digits start flashing.



- 3 Press A-button until the desired hour is displayed.
 - ▶ Press and hold to advance the hour fast.



- 4 Press B-button. The minute digits start flashing.



- 5 Press A-button until the desired minute is displayed.
 - ▶ Press and hold to advance the minute fast.



- 6 Press B-button. The clock is set, and the display moves to changing of the fuel mileage unit.

Instruments *(Continued)*

Changing of mileage units:

- 1 After clock setting, the mileage unit starts flashing.
- 2 Press A-button to select either km or mile.
- 3 Press B-button. The mileage unit is set, and the display moves to changing of the fuel mileage unit.

Changing of fuel mileage units:

- 1 After changing of the mileage unit, the fuel mileage unit starts flashing.
- 2 Press A-button to select either km/L or L/100km.
If the "mile" for mileage is selected, press the A-button to select either "mile/L" or "mile/gal".
- 3 Press B-button. The changing of the fuel mileage unit is set, and the display returns to the ordinary display.

Indicators

If one of these indicators does not come on when it should, have your dealer check for problems.

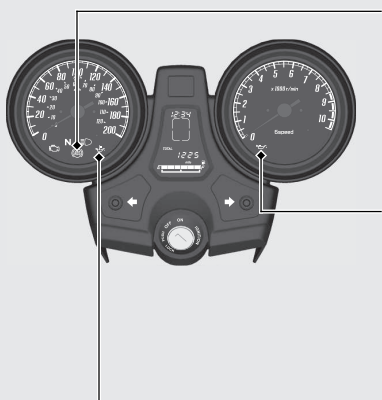

ABS (Anti-lock Brake System) indicator

Comes on when the ignition switch is turned to the ON position. Goes off when your speed reaches approximately 10 km/h (6 mph).

If it comes on while riding: ➔ P.88

Low oil pressure indicator

Comes on when the ignition switch is turned to the ON position.

Goes off when the engine starts.

If it comes on while engine is running: ➔ P.87

High oil temperature indicator

Comes on briefly when the ignition switch is turned to the ON position with the engine stop switch in the  (Run) position.

If it comes on while engine is running: ➔ P.86

Indicators (Continued)

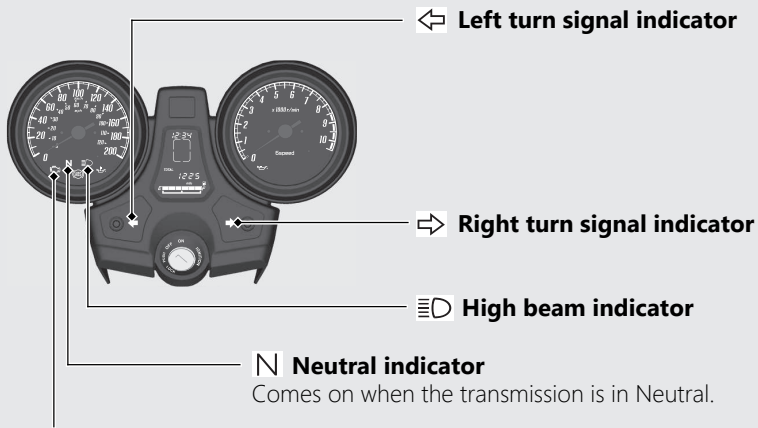

PGM-FI (Programmed Fuel Injection) malfunction indicator lamp (MIL)

Comes on briefly when the ignition switch is turned to the ON position with the engine stop switch in the  (Run) position.

If it comes on while engine is running:  **P.87**

Switches

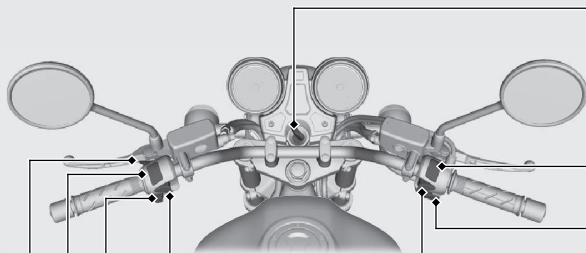



Horn button



Turn signal switch

- ▶ Pressing the switch turns the turn signal off.

Headlight dimmer switch

-  : High beam
-  : Low beam

 **PASS Passing light control switch**

Flashes the high beam headlight.



Start button



Hazard switch

Switchable when the ignition switch is turned to the ON position. Can be turned to off regardless of the ignition switch position.

- ▶ The signals continue flashing with the ignition switch is in the OFF or LOCK position after the hazard switch is on.

Ignition switch

Switches the electrical system on/off, locks the steering.

- ▶ Key can be removed when in the OFF or LOCK position.

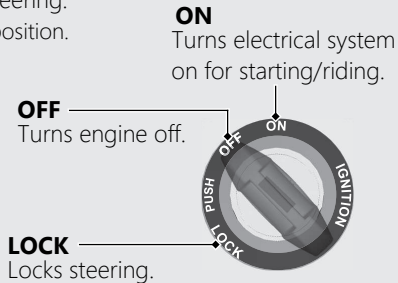

Engine stop switch

Should normally remain in the  (Run) position.

- ▶ In an emergency, switch to the  (Stop) position (the starter motor will not operate) to stop the engine.

Switches *(Continued)*

Steering Lock

Lock the steering when parking to help prevent theft.

A U-shaped wheel lock or similar device is also recommended.

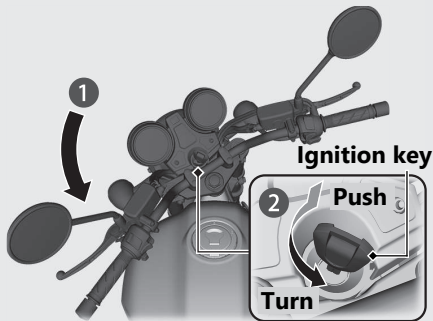

Locking

- 1 Turn the handlebar all the way to the left.
- 2 Push the key down, and turn the ignition switch to the LOCK position.
 - ▶ Jiggle the handlebar if the lock is difficult to engage.
- 3 Remove the key.

Unlocking

Insert the key, push it in, and turn the ignition switch to the OFF position.

Starting the Engine

Start your engine using the following procedure, regardless of whether the engine is cold or warm.

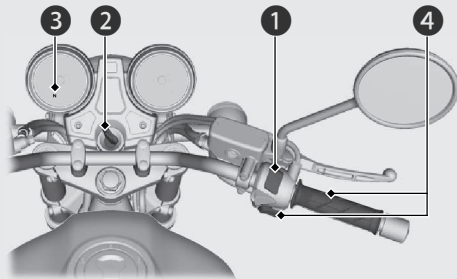

NOTICE

- If the engine does not start within 5 seconds, turn the ignition switch to the OFF position and wait 10 seconds before trying to start the engine again to recover battery voltage.
- Extended fast idling and revving the engine can damage the engine, and the exhaust system.
- Snapping the throttle or fast idling for more than about 5 minutes may cause exhaust pipe discoloration.
- The engine will not start if the throttle is fully open.

- 1 Make sure the engine stop switch is in the  (Run) position.
- 2 Turn the ignition switch to the ON position.
- 3 Shift the transmission to Neutral (**N** indicator comes on). Alternatively, pull in the clutch lever to start your motorcycle with the transmission in gear so long as the side stand is raised.
- 4 Press the start button with the throttle completely closed.

If the engine does not start:

- 1 Open the throttle fully and press the start button for 5 seconds.
- 2 Repeat the normal starting procedure.
- 3 If the engine starts, open the throttle slightly if idling is unstable.
- 4 If the engine does not start, wait 10 seconds before trying steps ① & ② again.

If Engine Will Not Start  **P.85**

Shifting Gears

Your motorcycle transmission has 6 forward gears in a one-down, five-up shift pattern.

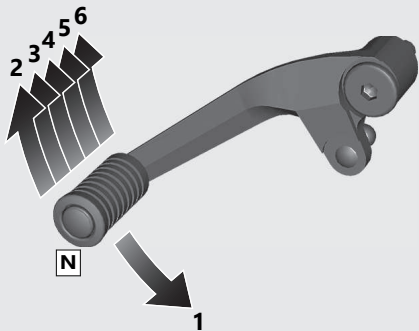

If you put the motorcycle in gear with the side stand down, the engine will shut off.

Recommended Shift Points

Shifting Up

From 1st to 2nd	20 km/h (12 mph)
From 2nd to 3rd	30 km/h (19 mph)
From 3rd to 4th	40 km/h (25 mph)
From 4th to 5th	50 km/h (31 mph)
From 5th to 6th	60 km/h (37 mph)

Shifting Down

From 6th to 5th	45 km/h (28 mph)
From 5th to 4th	35 km/h (22 mph)
From 4th to 3rd	25 km/h (16 mph)

NOTICE

Improper shifting can damage the engine, transmission, and drive train. Also, coasting or towing the motorcycle for long distances with the engine off can damage the transmission.

Refueling

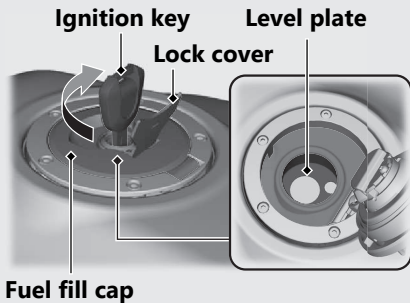

Do not fill with fuel above the level plate.

Fuel type: Unleaded gasoline only

Recommended fuel octane number:

Pump Octane Number (PON) 86 or higher.

Tank capacity: 16.8 L (4.44 US gal, 3.70 Imp gal)

Refueling and Fuel Guidelines ➔ P.12

Opening the Fuel Fill Cap

Open the lock cover, insert the ignition key, and turn it clockwise to open the fuel fill cap.

Closing the Fuel Fill Cap

- 1 After refueling, push the fuel fill cap closed until it locks.
- 2 Remove the ignition key and close the lock cover.
 - ▶ The ignition key cannot be removed if the fuel fill cap is not locked.

⚠ WARNING

Gasoline is highly flammable and explosive. You can be burned or seriously injured when handling fuel.

- Stop the engine, and keep heat, sparks, and flame away.
- Handle fuel only outdoors.
- Wipe up spills immediately.

Storage Equipment

Helmet Holder

Helmet holders are located on the left side below the seat and on the right side under the seat.

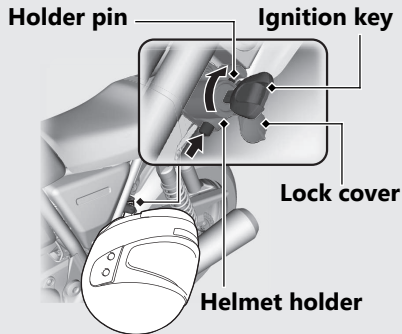

Unlocking

Open the lock cover, insert the ignition key and turn it clockwise.

Locking

- 1 Hang your helmet on the holder pin and push it in to lock.
- 2 Remove the key and close the lock cover.
 - ▶ Use the helmet holder only when parked.

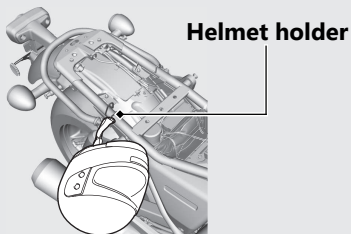

Removing the Seat ➔ P.61

⚠ WARNING

Riding with a helmet attached to the holder can interfere with the rear wheel or suspension and could cause a crash in which you can be seriously hurt or killed.

Use the helmet holder only while parked. Do not ride with a helmet secured by the holder.

Document Bag

A document bag is located on the underside of the seat.

Under side of the seat

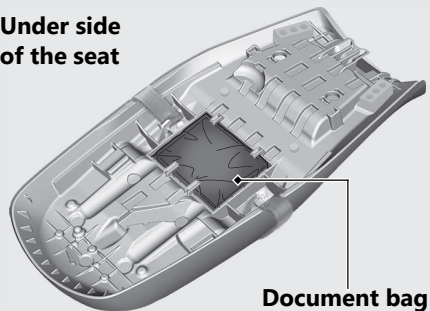

Removing the Seat ➔ P.61

Storage Equipment *(Continued)*

Tool Kit

Center compartment

- ▶ Do not store any items that are flammable or susceptible to heat damage.

Rubber strap

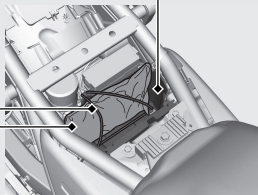

Tool kit

A tool kit is located under the seat.

- ▶ The tool kit is held in the center compartment by a rubber strap.

Removing the Seat ➡ P.61

Maintenance

Please read "Importance of Maintenance" and "Maintenance Fundamentals" carefully before attempting any maintenance. Refer to "Specifications" for service data.

An optional larger tool kit may be available.
Check with your Honda dealer's parts department.

Importance of Maintenance	P. 40	Clutch	P. 77
Maintenance Schedule	P. 41	Throttle	P. 78
Maintenance Fundamentals	P. 44	Crankcase Breather	P. 79
Removing & Installing Body Components ..	P. 58	Other Adjustments	P. 80
Battery	P. 58	Adjusting the Headlight Aim	P. 80
Clip	P. 60	Adjusting the Clutch and Brake Levers	P. 81
Seat	P. 61	Adjusting the Front Suspension.....	P. 82
Side Cover.....	P. 62	Adjusting the Rear Suspension	P. 83
Spark Plug	P. 63		
Engine Oil	P. 65		
Air Cleaner	P. 69		
Brakes	P. 71		
Side Stand	P. 73		
Drive Chain	P. 74		

Importance of Maintenance

Importance of Maintenance

Keeping your motorcycle well-maintained is absolutely essential to your safety and to protect your investment, obtain maximum performance, avoid breakdowns, and reduce air pollution. Maintenance is the owner's responsibility. Be sure to inspect your motorcycle before each ride, and perform the periodic checks specified in the Maintenance Schedule. ➤ P. 41

⚠ WARNING

Improperly maintaining your motorcycle or failing to correct a problem before you ride can cause a crash in which you can be seriously hurt or killed.

Always follow the inspection and maintenance recommendations and schedules in this owner's manual.

Maintenance Safety

Always read the maintenance instructions before you begin each task, and make sure that you have the tools, parts, and skills required. We cannot warn you of every conceivable hazard that can arise in performing maintenance. Only you can decide whether or not you should perform a given task.

Follow these guidelines when performing maintenance.

- Stop the engine and remove the key.
- Place your motorcycle on a firm, level surface using the side stand, center stand or a maintenance stand to provide support.
- Allow the engine, muffler, brakes, and other high-temperature parts to cool before servicing as you can get burned.
- Run the engine only when instructed, and do so in a well-ventilated area.

Maintenance Schedule

The maintenance schedule specifies the maintenance requirements necessary to ensure safe, dependable performance, and proper emission control.

Maintenance work should be performed in accordance with Honda's standards and specifications by properly trained and equipped technicians. Your dealer meets all of these requirements. Keep an accurate record of maintenance to help ensure that your motorcycle is properly maintained. Make sure that whomever performs the maintenance completes this record.

All scheduled maintenance is considered a normal owner operating cost and will be charged to you by your dealer. Retain all receipts. If you sell the motorcycle, these receipts should be transferred with the motorcycle to the new owner.

Maintenance Schedule

















































Items		Frequency*1								Regular Replace	Refer to page
		× 1,000 mi	0.6	4	8	12	16	20	24		
		× 1,000 km	1.0	6.4	12.8	19.2	25.6	32.0	38.4		
Emission-Related Items	Fuel Line	⚙️			I		I		I		-
	Throttle Operation	⚙️			I		I		I		78
	Air Cleaner *2					I			I		69
	Crankcase Breather *3			C	C	C	C	C	C		79
	Spark Plug				R		R		R		63
	Valve Clearance	⚙️				I			I		-
	Engine Oil		R		R		R		R	1 Year	67
	Engine Oil Filter		R				R				67
	Engine Idle Speed	⚙️			I		I		I		-
	Secondary Air Supply System	⚙️					I				-

Maintenance Level

- ⚙️ : Intermediate. We recommend service by your dealer, unless you have the necessary tools and are mechanically skilled. Procedures are provided in an official Honda Service Manual (➡ P. 120).
- ⚙️ : Technical. In the interest of safety, have your motorcycle serviced by your dealer.

Maintenance Legend

- I : Inspect (clean, adjust, lubricate, or replace, if necessary)
- L : Lubricate
- R : Replace
- C : Clean

Items		Frequency*1								Regular Replace	Refer to page
		× 1,000 mi	0.6	4	8	12	16	20	24		
		× 1,000 km	1.0	6.4	12.8	19.2	25.6	32.0	38.4		
Non-Emission-Related Items	Drive Chain			Every 600 mi (1,000 km):  							74
	Brake Fluid *4									2 Years	71
	Brake Pads Wear										72
	Brake System										44
	Headlight Aim										80
	Clutch System										81
	Clutch Fluid*4									2 Years	77
	Side Stand										73
	Suspension										82, 83
	Nuts, Bolts, Fasteners										–
	Wheels/Tires										54
	Steering Head Bearings										–

Notes:

*1 : At higher odometer readings, repeat at the frequency interval established here.

*2 : Service more frequently when riding in unusually wet or dusty areas.

*3 : Service more frequently when riding in rain or at full throttle.

*4 : Replacement requires mechanical skill.

Pre-ride Inspection

To ensure safety, it is your responsibility to perform a pre-ride inspection and make sure that any problem you find is corrected. A pre-ride inspection is a must, not only for safety, but because having a breakdown, or even a flat tire, can be a major inconvenience.

Check the following items before you get on your motorcycle:

- Tire tread wear and air pressures are within limits. ➔ P. 54
- Lights, horn, and turn signals operate normally.
- Check the condition of the drive chain. Adjust slack and lubricate as needed. ➔ P. 52

Check the following items if you are carrying a passenger or cargo:

- Combined weight is within load limits. ➔ P. 124
- Cargo is secured properly.

- Suspension is adjusted to suit load. ➔ P. 82, ➔ P. 83

Check the following items after you get on your motorcycle:

- Throttle action moves smoothly without binding. ➔ P. 78
- Brake lever and pedal operate normally.
- Check the fuel level and refuel when needed. ➔ P. 12, ➔ P. 35
- Engine stop switch functions properly. ➔ P. 30

Check the following items at regular intervals:

- Oil level is between the upper and lower level marks. ➔ P. 65
- Brake fluid level is

Front: above the LOWER level mark. ➔ P. 71

Rear: between the UPPER and LOWER level marks. ➔ P. 71

- Clutch fluid level is above the LOWER level mark. ➔ P. 77
- Side stand functions properly. ➔ P. 73

Periodic Checks

You should also perform other periodic maintenance checks at least once a month regardless of how often you ride, or more often if you ride frequently.

Also, check the odometer reading against the Maintenance Schedule and perform all maintenance that is due. ➤ P. 41

Tires and wheels	Check the air pressure (➤ P. 54), examine tread for wear and damage (➤ P. 54), and check the wheels for damage.
Fluid levels	Check the engine oil level (➤ P. 65), clutch fluid level (➤ P. 77), and brake fluid level (➤ P. 71).
Lights	Check that the headlight, brake light/taillight and turn signals are working properly.
Controls	Check the freeplay of the throttle grip (➤ P. 78).
Drive chain	Check the slack (➤ P. 74), adjust the slack (➤ P. 75), and lubricate (➤ P. 53) as needed.
Fuses	Check that you have a full supply of spare fuses.
Nuts & bolts	Check the major nuts and bolts, and tighten as needed.
Crankcase Breather	Service the crankcase breather more frequently if your motorcycle is ridden in the rain or often at full throttle. Service the breather if you can see deposits in the transparent section of the drain tube (➤ P. 79).

Replacing Parts

Always use Honda Genuine Parts or their equivalents to ensure reliability and safety.

When ordering colored components, specify the model name, color, and code mentioned on the color label. The color label is attached to the frame under the seat. ➤ P. 61

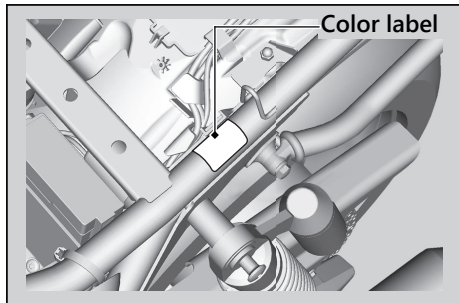

⚠️ WARNING

Installing non-Honda parts may make your motorcycle unsafe and cause a crash in which you can be seriously hurt or killed.

Always use Honda Genuine Parts or equivalents that have been designed and approved for your motorcycle.

Battery

Your motorcycle has a maintenance-free type battery. You do not have to check the battery electrolyte level or add distilled water. Clean the battery terminals if they become dirty or corroded.

Do not remove the battery cap seals. There is no need to remove the cap when charging.

NOTICE

An improperly disposed of battery can be harmful to the environment and human health. Always confirm local regulations for proper battery disposal instruction.

What to do in an emergency

If any of the following occur, immediately see your doctor.

- Electrolyte splashes into your eyes:
 - ▶ Wash your eyes repeatedly with cool water for at least 15 minutes. Using water under pressure can damage your eyes.

- Electrolyte splashes onto your skin:
 - ▶ Remove affected clothing and wash your skin thoroughly using water.
- Electrolyte splashes into your mouth:
 - ▶ Rinse mouth thoroughly with water, and do not swallow.

WARNING

The battery gives off explosive hydrogen gas during normal operation.

A spark or flame can cause the battery to explode with enough force to kill or seriously hurt you.

Wear protective clothing and a face shield, or have a skilled mechanic do the battery servicing.

| Cleaning the Battery Terminals

1. Remove the battery. ➤ P. 58
2. If the terminals are starting to corrode and are coated with a white substance, wash with warm water and wipe clean.
3. If the terminals are heavily corroded, clean and polish the terminals with a wire brush or sandpaper. Wear safety glasses.

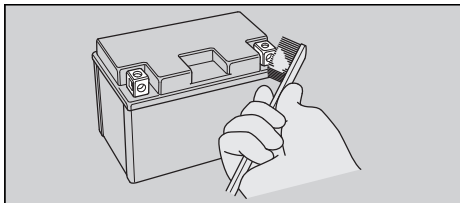

4. After cleaning, reinstall the battery.

The battery has a limited life span. Consult your dealer about when you should replace the battery. Always replace the battery with another maintenance-free battery of the same type.

| Charging

If you use electrical accessories that drain the battery or you do not ride frequently, we recommend that you charge the battery every 30 days using a charger designed specifically for your Honda, which can be purchased from your dealer. Read the information that came with your battery charger and follow the instructions on the battery. Avoid using an automobile-type battery charger, as these can overheat a motorcycle battery and cause permanent damage.

Make sure the ignition switch is in the OFF position before charging the battery.

NOTICE

Improper charging can damage the battery. If you can't charge the battery or it appears unable to hold a charge, contact your dealer.

NOTICE

Jump starting using an automobile battery can damage your motorcycle's electrical system and is not recommended. Bump starting is also not recommended.

NOTICE

Installing non-Honda electrical accessories can overload the electrical system, discharging the battery and possibly damaging the system.

Fuses

Fuses protect the electrical circuits on your motorcycle. If something electrical on your motorcycle stops working, check for and replace any blown fuses. ➤ P. 101

Inspecting and Replacing Fuses

Turn the ignition switch to the OFF position to remove and inspect fuses. If a fuse is blown, replace with a fuse of the same rating. For fuse ratings, see "Specifications." ➤ P. 126

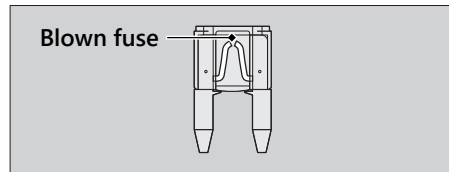
**NOTICE**

Replacing a fuse with one that has a higher rating greatly increases the chance of damage to the electrical system.

If a fuse fails repeatedly, you likely have an electrical fault. Have your motorcycle inspected by your dealer.

Engine Oil

Engine oil consumption varies and oil quality deteriorates according to riding conditions and time elapsed.

Check the engine oil level regularly, and add the recommended engine oil if necessary. Dirty oil or old oil should be changed as soon as possible.

Selecting the Engine Oil

For recommended engine oil, see "Specifications." P. 125

If you use non-Honda engine oil, check the label to make sure that the oil satisfies all of the following standards:

- JASO T 903 standard^{*1}: MA
- SAE standard^{*2}: 10W-30
- API classification^{*3}: SG or higher

^{*1}: The JASO T 903 standard is an index for engine oils for 4-stroke motorcycle engines. There are two classes: MA and MB. For example, the following label shows the MA classification.

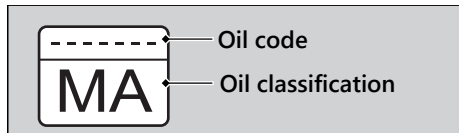

- ^{*2}: The SAE standard grades oils by their viscosity.
- ^{*3}: The API classification specifies the quality and performance rating of engine oils. Use SG or higher oils, excluding oils marked as "Energy Conserving" or "Resource Conserving" on the circular API service symbol.

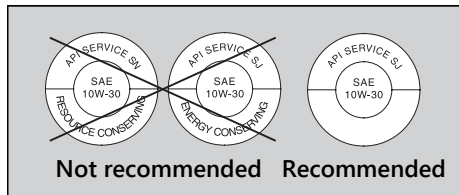

Brake Fluid (Clutch Fluid)

Do not add or replace brake fluid, except in an emergency. Use only fresh brake fluid from a sealed container. If you do add fluid, have the brake and clutch system serviced by your dealer as soon as possible.

NOTICE

Brake fluid can damage plastic and painted surfaces. Wipe up spills immediately and wash thoroughly.

Recommended brake fluid:

Honda DOT 4 Brake Fluid or equivalent

WARNING

Clean filler cap before removing. Use only DOT 4 fluid from a sealed container.

Drive Chain

The drive chain must be inspected and lubricated regularly. Inspect the chain more frequently if you often ride on bad roads, ride at high speed, or ride with repeated fast acceleration. ➤ P. 74

If the chain does not move smoothly, makes strange noises, has damaged rollers, has loose pins, has missing O-rings, or kinks, have the chain inspected by your dealer.

Also inspect the drive sprocket and driven sprocket. If either has worn or damaged teeth, have the sprocket replaced by your dealer.

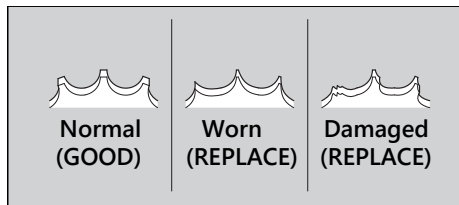

NOTICE

Use of a new chain with worn sprockets will cause rapid chain wear.

Cleaning and Lubricating

After inspecting the slack, clean the chain and sprockets while rotating the rear wheel. Use a dry cloth with chain cleaner designed specifically for O-ring chains, or neutral detergent. Use a soft brush if the chain is dirty.

After cleaning, wipe dry and lubricate with the recommended lubricant.

Recommended lubricant:

Pro Honda HP Chain Lube or equivalent

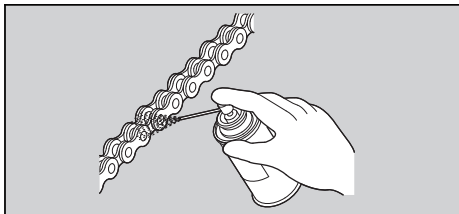

Do not use a steam cleaner, a high pressure cleaner, a wire brush, volatile solvent such as gasoline and benzene, abrasive cleaner, chain cleaner or lubricant NOT designed specifically for O-ring chains as these can damage the rubber O-ring seals.

Avoid getting lubricant on the brakes or tires. Avoid applying excess chain lubricant to prevent spray onto your clothes and the motorcycle.

Crankcase Breathers

Service more frequently when riding in rain, at full throttle, or after the motorcycle is washed or overturned. Service if the deposit level can be seen in the transparent section of the drain tube.

If the drain tube overflows, the air filter may become contaminated with engine oil causing poor engine performance. ➔ P. 79

Tires (Inspecting/Replacing)

Checking the Air Pressure

Visually inspect your tires and use an air pressure gauge to measure the air pressure at least once a month or any time you think the tires look low. Always check air pressure when your tires are cold.

Even if the direction of the valve stem is changed, do not return it to the original position. Have your motorcycle inspected by your dealer.

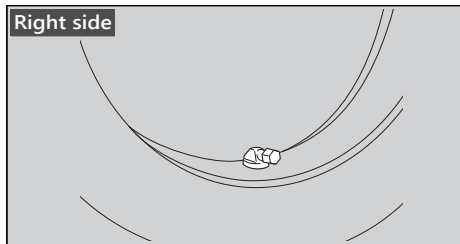

Inspecting for Damage

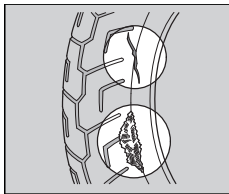

Inspect the tires for cuts, slits, or cracks that exposes fabric or cords, or nails or other foreign objects embedded in the side of the tire or the tread.

Also inspect for any unusual bumps or bulges in the side walls of the tires.

Inspecting for Abnormal Wear

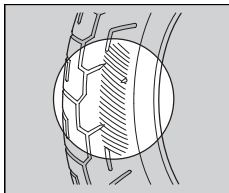

Inspect the tires for signs of abnormal wear on the contact surface.

Inspecting Tread Depth

Inspect the tread wear indicators. If they become visible, replace the tires immediately. For safe riding, you should replace the tires when the minimum tread depth is reached.

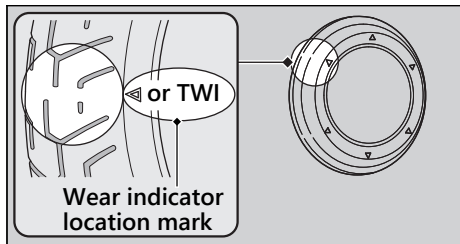

⚠️ WARNING

Riding on tires that are excessively worn or improperly inflated can cause a crash in which you can be seriously hurt or killed.

Follow all instructions in this owner's manual regarding tire inflation and maintenance.

Maintenance Fundamentals

Have your tires replaced by your dealer. For recommended tires, air pressure and minimum tread depth, see "Specifications."

➤ P. 125

Follow these guidelines whenever you replace tires.

- Use the recommended tires or equivalents of the same size, construction, speed rating, and load range.
- Have the wheel balanced with Honda Genuine balance weights or equivalent after the tire is installed.
- Do not install a tube inside a tubeless tire on this motorcycle. Excessive heat build-up can cause the tube to burst.
- Use only tubeless tires on this motorcycle. The rims are designed for tubeless tires, and during hard acceleration or braking, a tube-type tire could slip on the rim and cause the tire to rapidly deflate.

WARNING

Installing improper tires on your motorcycle can adversely affect handling and stability, and can cause a crash in which you can be seriously hurt or killed.

Always use the size and type of tires recommended in this owner's manual.

Tire Service Life

The service life of your tires is dependent on many factors, including, but not limited to, riding habits, road conditions, vehicle loading, tire air pressure, maintenance history, speed, and environmental conditions (even when the tires are not in use).

In addition to your regular inspections and maintenance, it is recommended that you have annual inspections performed once the tires reach 5 years old. It is also recommended that all tires be removed from service after 10 years from the date of manufacture, regardless of their condition or state of wear.

The last four digits of the TIN (tire identification number) indicate the date of manufacture.

Tire Identification Number (TIN)

The tire identification number (TIN) is a group of numbers and letters located on the sidewall of the tire.

① ② ③

DOT XXXX XXXX 22 09

DOT: This indicates that the tire meets all requirements of the U.S. Department of Transportation.

- ① XXXX: Factory code
- ② XXXX: Tire type code
- ③ 22 09: Date of manufacture (week & year).
Example: week 22 in year 09.

Tire Labeling Example

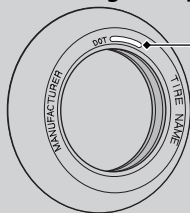

Tire identification number (TIN)

Battery

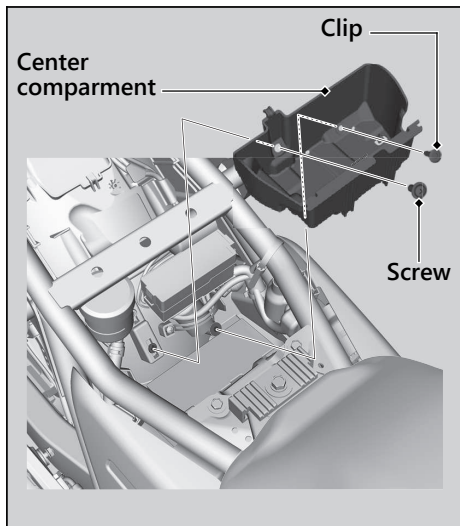

Removal

Make sure the ignition switch is in the OFF position.

1. Remove the seat. ➔ P. 61
2. Remove the tool kit.
3. Remove the screw and clip. ➔ P. 60
4. Remove the center compartment.

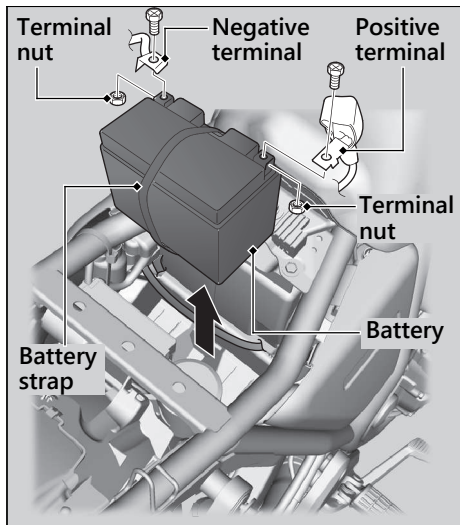

5. Disconnect the negative \ominus terminal from the battery.
6. Disconnect the positive \oplus terminal from the battery.
7. Lift the battery strap with one hand while supporting the battery.
8. Remove the battery taking care not to drop the terminal nuts.

Installation

Install the parts in the reverse order of removal. Always connect the positive \oplus terminal first. Make sure that bolts and nuts are tight.

Make sure the clock information is correct after the battery is reconnected. ► P. 25
 For proper handling of the battery, see "Maintenance Fundamentals." ► P. 47
 "Battery Goes Dead." ► P. 98

Clip

Removal

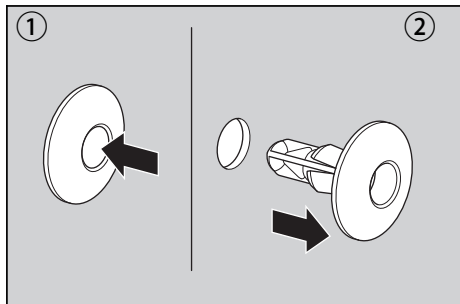

1. Press down on the center pin to release the lock.
2. Pull the clip out of the hole.

Installation

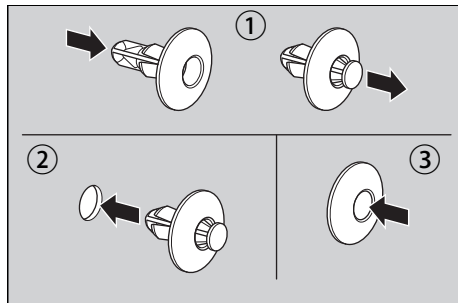

1. Push the bottom of the center pin.
2. Insert the clip into the hole.
3. Press down on the center pin to lock the clip.

Seat

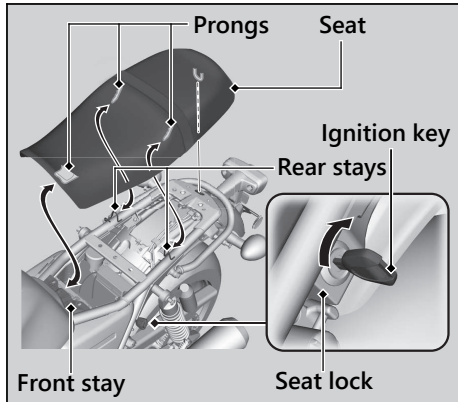

Removal

1. Insert the ignition key into the seat lock, and turn and hold the key clockwise to unlock the seat.
2. Pull the seat back and up.

Installation

1. Insert the prongs into the front and rear stays on the frame.
2. Push forward and down on the rear of the seat until it locks in place. Make sure that the seat is locked securely in position to pull it up lightly.

The seat locks automatically when closed. Take care not to lock your key in the underseat compartment.

Side Cover

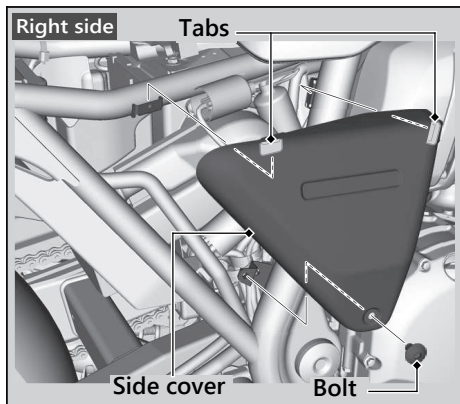

The right and left side covers can be removed in the same manner.

Removal

1. Remove the bolt.
2. Remove the side cover by releasing the tabs.

Installation

Install the parts in the reverse order of removal.

Changing Spark Plug

For the recommended spark plugs, see “Specifications.” P. 125

Use only the recommended type of spark plugs in the recommended heat range.

NOTICE

Using a spark plug with an improper heat range can cause engine damage.

1. Disconnect the spark plug caps from the spark plugs.
2. Clean any dirt from around the spark plug bases.
3. Remove the spark plugs using a suitable spark plug wrench.

Spark plug cap

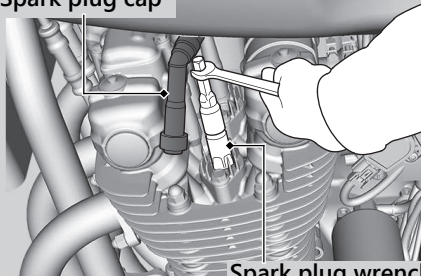

Spark plug wrench

4. Install the new spark plugs. With the plug washers attached, thread the spark plugs in by hand to prevent cross-threading.

5. Tighten the spark plug:
 - If the old plug is good:
1/5 turn after it seats
 - If installing a new plug, tighten it twice to prevent loosening:
 - a) First, tighten the plug:
NGK: 1/4 turn after it seats.
 - b) Then loosen the plug.
 - c) Next, tighten the plug again:
1/5 turn after it seats.

NOTICE

An improperly tightened spark plug can damage the engine. If a plug is too loose, a piston may be damaged. If a plug is too tight, the threads may be damaged.

6. Install the parts in the reverse order of removal.
 - When reinstalling the spark plug caps, take care to avoid pinching any cables or wires.

Checking the Engine Oil

1. If the engine is cold, idle the engine for 3 to 5 minutes.
2. Turn the ignition switch to the OFF position and wait for 2 to 3 minutes.
3. Place your motorcycle on its center stand on a firm, level surface.
4. Check that the oil level is between the upper level and lower level marks on the oil level inspection window.
 - ▶ If required, clean the inspection window by turning the wiper.

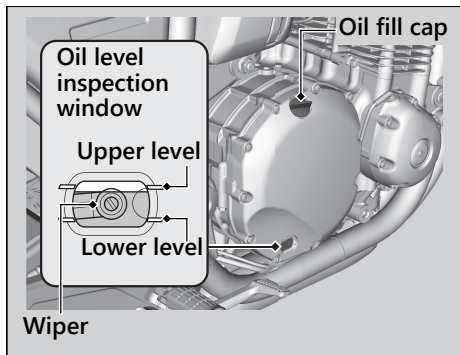

Adding Engine Oil

If the engine oil is below or near the lower level mark, add the recommended engine oil.

► P. 50, ► P. 125

1. Remove the oil fill cap. Add the recommended oil until it reaches the upper level mark.
 - Place your motorcycle on its center stand on a firm, level surface when checking the oil level.
 - Do not overfill above the upper level mark.
 - Make sure no foreign objects enter the oil filler opening.
 - Wipe up any spills immediately.

2. Securely reinstall the oil fill cap.

NOTICE

Overfilling with oil or operating with insufficient oil can cause damage to your engine. Do not mix different brands and grades of oil. They may affect lubrication and clutch operation.

For the recommended oil and oil selection guidelines, see “Maintenance Fundamentals.”

► P. 50

Changing Engine Oil & Filter

Changing the oil and filter requires special tools. We recommend that you have your motorcycle serviced by your dealer.

Use a new Honda Genuine oil filter or equivalent specified for your model.

NOTICE

Using the wrong oil filter can result in serious damage to the engine.

1. If the engine is cold, idle the engine for 3 to 5 minutes.
2. Turn the ignition switch to the OFF position and wait for 2 to 3 minutes.
3. Place your motorcycle on its center stand on a firm, level surface.
4. Place a drain pan under the drain bolt.

5. Remove the oil fill cap, drain bolt, and sealing washer to drain the oil.

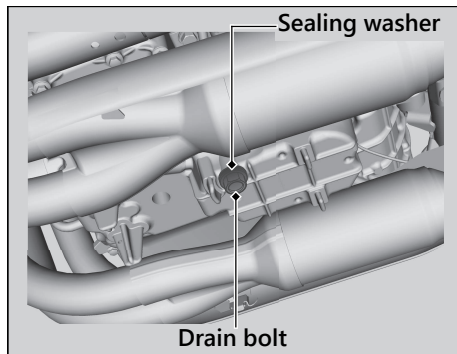

Engine Oil ► Changing Engine Oil & Filter

- Remove the oil filter with a filter wrench and let the remaining oil drain out. Make sure the prior seal is not stuck to the engine.
 - Discard the oil and oil filter at an approved recycling center.

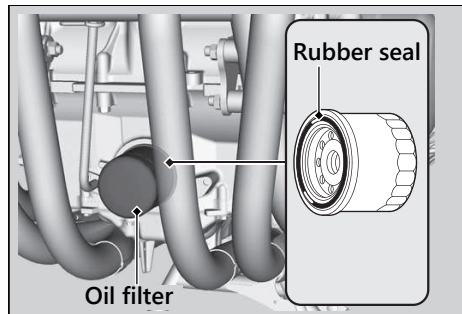

- Apply a thin coat of engine oil to the rubber seal of a new oil filter.

- Install the new oil filter and tighten.

Torque: 26 N·m (2.7 kgf·m, 19 lbf·ft)

- Install a new sealing washer onto the drain bolt. Tighten the drain bolt.

Torque: 30 N·m (3.1 kgf·m, 22 lbf·ft)

- Fill the crankcase with the recommended oil (► P. 50, ► P. 125) and install the oil fill cap.

Required oil

When changing oil & engine oil filter:

3.9 L (4.1 US qt, 3.4 Imp qt)

When changing oil only:

3.8 L (4.0 US qt, 3.3 Imp qt)

- Check the oil level. ► P. 65
- Check that there are no oil leaks.

Inspecting & Changing Air Cleaner Element

Use a new Honda Genuine air cleaner element or equivalent specified for your motorcycle.

NOTICE

Using the wrong air cleaner element can result in serious damage to the engine.

1. Remove the right side cover. ▣ P. 62
2. Remove the attaching screws and air cleaner housing cover.
3. Pull out the air cleaner element and check it for any damage.
 - ▶ Blow away the remaining dust by applying compressed air from the outside of the air cleaner element.
 - ▶ Replace the air cleaner element if it is excessively dirty, torn or damaged.

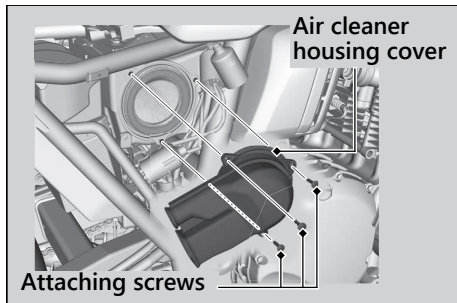

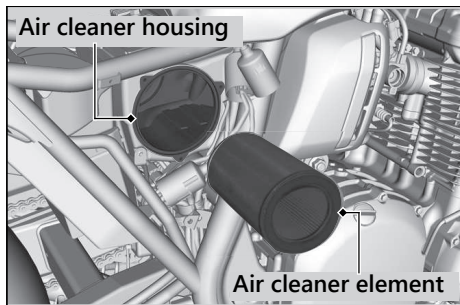

4. Thoroughly clean the inside of the air cleaner housing.
5. Install the air cleaner element or a new one.
6. Install the parts in the reverse order of removal.

Checking Brake Fluid

1. Place your motorcycle in an upright position on a firm, level surface.
2. **Front** Check that the brake fluid reservoir is horizontal and that the fluid level is above the LOWER level mark.
3. **Rear** Remove the seat. ➔ P. 61

4. **Rear** Check that the brake fluid reservoir is horizontal and that the fluid level is between the LOWER level and UPPER level marks.

If the brake fluid level in either reservoir is below the LOWER level mark or the brake lever and pedal freeplay becomes excessive, inspect the brake pads for wear.

If the brake pads are not worn, you most likely have a leak. Have your motorcycle inspected by your dealer.

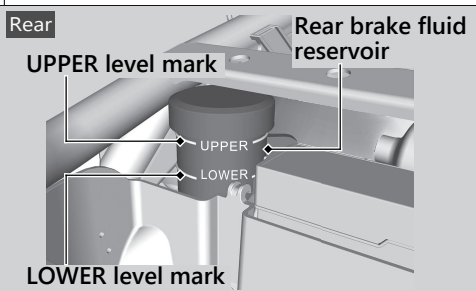
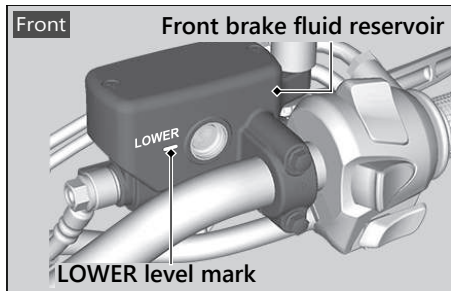

Inspecting the Brake Pads

Check the condition of the brake pad wear indicators.

Front The pads need to be replaced if a brake pad is worn to the bottom of the indicator.

Rear The pads need to be replaced if a brake pad is worn to the indicator.

1. **Front** Inspect the brake pads from below the brake caliper.
 - Always inspect both left and right brake calipers.

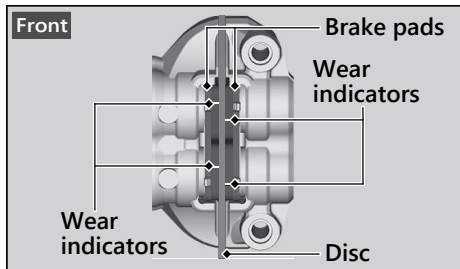

2. **Rear** Inspect the brake pads from the rear right of the motorcycle.

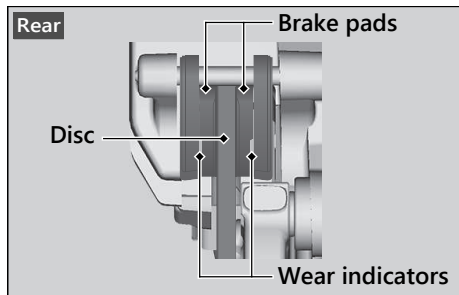

If necessary have the pads replaced by your dealer.

Always replace both left and right brake pads at the same time.

Checking the Side Stand

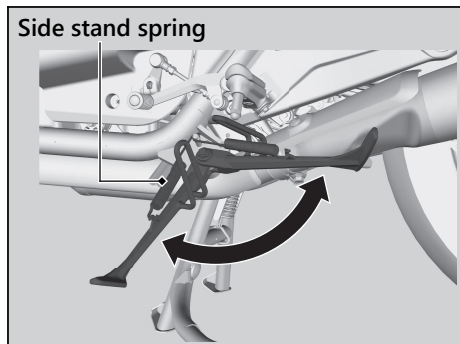

1. Check that the side stand operates smoothly. If the side stand is stiff or squeaky, clean the pivot area and lubricate the pivot bolt with clean grease.
2. Check the spring for damage or loss of tension.
3. Sit on the motorcycle, shift the transmission to Neutral, and raise the side stand.
4. Start the engine, pull the clutch lever in, and shift the transmission into gear.
5. Lower the side stand all the way. The engine should stop as you lower the side stand. If the engine doesn't stop, have your motorcycle inspected by your dealer.

Inspecting the Drive Chain Slack

Check the drive chain slack at several points along the chain. If the slack is not constant at all points, some links may be kinked and binding.

Have the chain inspected by your dealer.

1. Shift the transmission to Neutral. Stop the engine.
2. Place your motorcycle on its center stand on a firm, level surface.
3. Check the slack in the lower half of the drive chain midway between the sprockets.

Drive chain slack:

25 - 35 mm (1.0 - 1.4 in)

- ▶ Do not ride your motorcycle if the slack exceeds 50 mm (2.0 in).

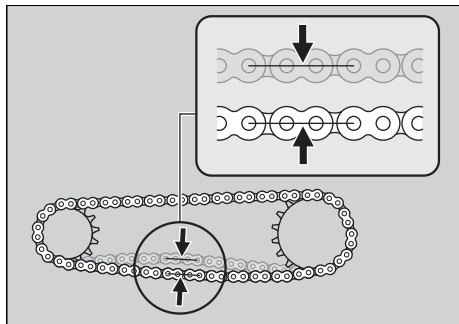

4. Rotate the rear wheel and check that the chain moves smoothly.
5. Inspect the sprockets. ➤ P. 52
6. Clean and lubricate the drive chain. ➤ P. 53

Adjusting the Drive Chain Slack

Adjusting the chain requires special tools. Have the drive chain slack adjusted by your dealer.

When adjusting the drive chain slack, be careful not to damage the wheel speed sensor and pulser ring.

1. Shift the transmission to Neutral. Stop the engine.
2. Place your motorcycle on its center stand on a firm, level surface.
3. Loosen the rear axle nut.
4. Loosen the lock nuts on both adjusting bolts.

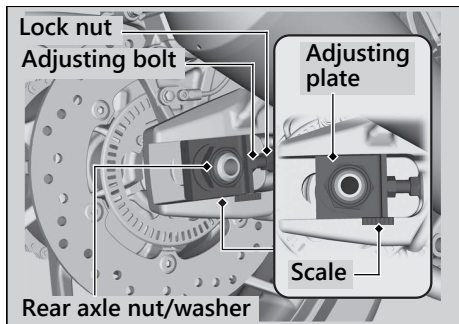

5. Turn both adjusting bolts an equal number of turns until the correct drive chain slack is obtained. Turn the adjusting bolts counterclockwise to tighten the chain. Turn the adjusting bolts clockwise and push the rear wheel toward the front to provide more slack. Adjust the slack at a point midway between the drive sprocket and the driven sprocket. Check the drive chain slack. ► P. 74

Drive Chain ► Adjusting the Drive Chain Slack

- Check rear axle alignment by making sure the end of the chain adjusting plate aligns with the scale graduations on both sides of the swingarm. Both marks should correspond. If the axle is misaligned, turn the right or left adjusting bolts until the marks are aligned and recheck chain slack.
- Tighten the rear axle nut.

Torque: 113 N·m (11.5 kgf·m, 83 lbf·ft)

- Hold the adjusting bolts and tighten the lock nuts.
- Recheck drive chain slack.

If a torque wrench was not used for installation, see your dealer as soon as possible to verify proper assembly. Improper assembly may lead to loss of braking capacity.

Checking the Drive Chain Wear

Check the chain wear label when adjusting the drive chain. If the end of the chain adjusting plate enters the red zone on the label after the chain has been adjusted to the proper slack, the chain is excessively worn and must be replaced.

Chain: DID50VA11 or RK50HFOZ6

If necessary have the drive chain replaced by your dealer.

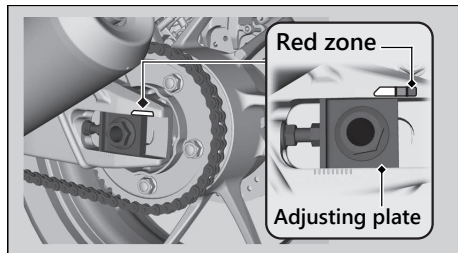

Checking Clutch Fluid

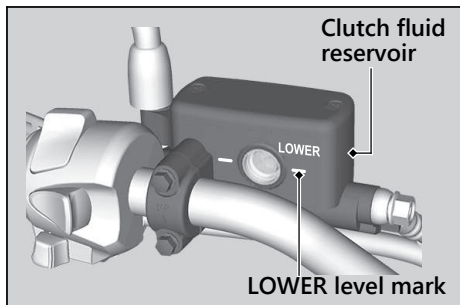

1. Place your motorcycle in an upright position on a firm, level surface.
2. Check that the clutch fluid reservoir is horizontal and that the fluid level is above the LOWER level mark.

If the fluid level is low or if you find fluid leaks, or deterioration or cracks in the hoses and fittings, have the clutch system serviced by your dealer.

Checking the Throttle

With the engine off, check that the throttle rotates smoothly from fully closed to fully open in all steering positions and throttle freeplay is correct. If the throttle does not move smoothly, close automatically, or if the cable is damaged, have the motorcycle inspected by your dealer.

Freeplay at the throttle grip flange:

2 - 6 mm (0.1 - 0.2 in)

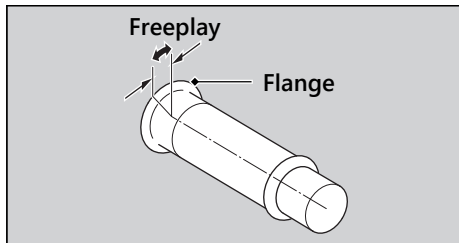

Adjusting the Throttle Freeplay

1. Loosen the lock nut.
2. Turn the adjuster until the freeplay is 2 - 6 mm (0.1 - 0.2 in).
3. Tighten the lock nut, and inspect the throttle action again.

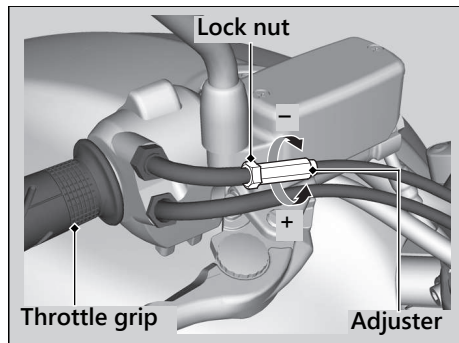

Cleaning the Crankcase Breather

1. **Left**
Remove the left side cover. ➤ P. 62
2. Place a suitable container under the crankcase breather tubes.
3. Remove the crankcase breather tube plugs from the tubes.
4. Drain deposits into a suitable container.
5. Install the crankcase breather tube plugs.

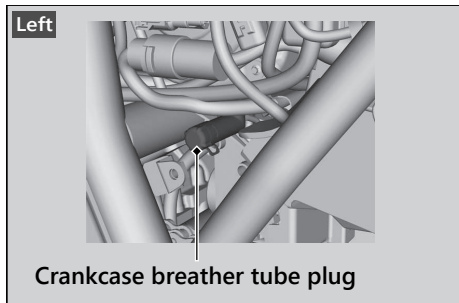
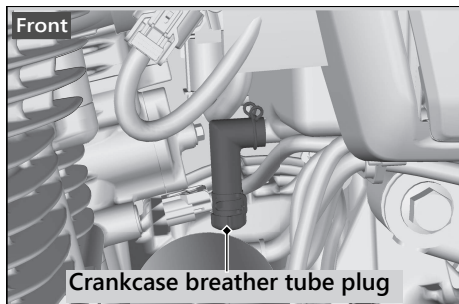

Adjusting the Headlight Aim

You can adjust vertical aim of the headlight for proper alignment. Loosen the bolts and move the headlight case as necessary. Tighten the bolts after adjustment. Obey local laws and regulations.

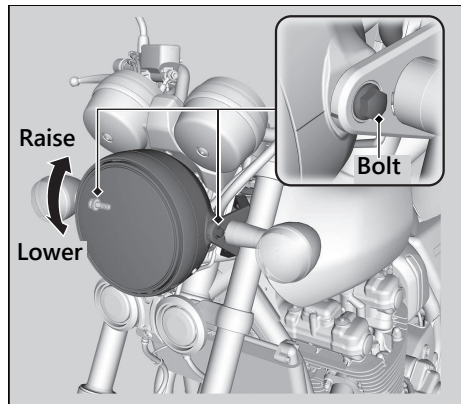

Adjusting the Clutch and Brake Levers

You can adjust the distances between the tip of the clutch lever and handle grip, and between the tip of the brake lever and handle grip.

Adjustment method

Turn the adjuster until the numbers align with the index mark while pushing the lever forward in the desired position.

After adjustment, check that the levers operate correctly before riding.

NOTICE

Do not turn the adjuster beyond its natural limit.

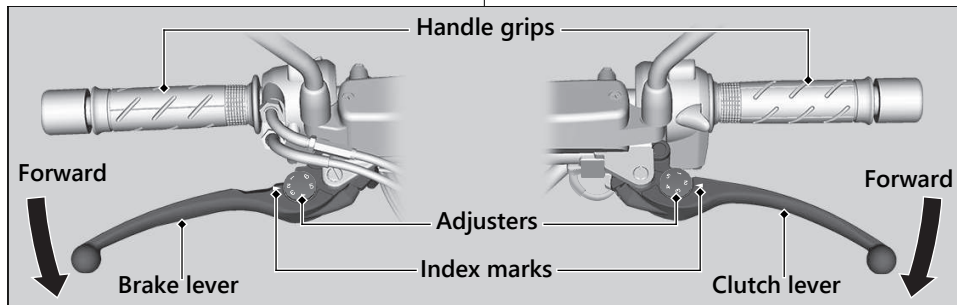

Adjusting the Front Suspension

I Spring Preload

You can adjust the spring preload by the adjuster to suit the load or the road surface. Turn clockwise to increase spring preload (hard), or turn counterclockwise to decrease spring preload (soft).

The standard position is the 2nd groove from the top aligning with the top surface of the fork bolts.

NOTICE

Do not turn the adjuster beyond its limits. Adjust both left and right forks to the same spring preload.

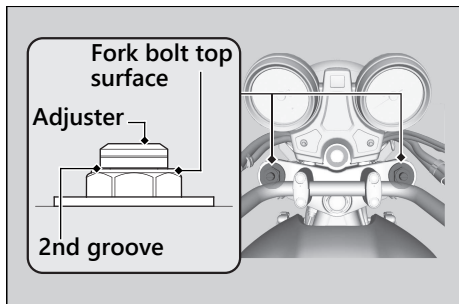

Adjusting the Rear Suspension

Adjusting the suspension requires a pin spanner. We recommend that you have your motorcycle serviced by your dealer.

Spring Preload

You can adjust the spring preload by the adjuster to suit the load or the road surface. Turn the adjuster using the pin spanner. Position 1 is for a decreased spring preload (soft), or turn to the position 3 to 5 for a increased spring preload (hard). The standard position is 2.

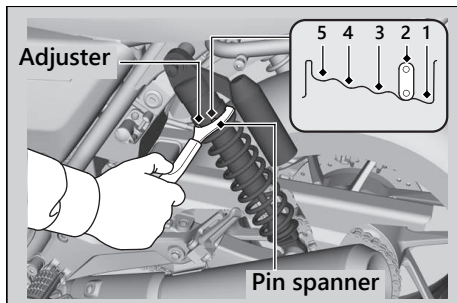

NOTICE

Do not turn the adjuster beyond its limits. Adjust both left and right shock absorbers to the same spring preload.

NOTICE

The rear shock absorber damper unit contains high pressure nitrogen gas. Do not attempt to disassemble, service, or improperly dispose of the damper. See your dealer.

Troubleshooting

Engine Will Not Start	P. 85	
Overheating (High oil temperature indicator is on)	P. 86	
Warning Indicators On or Flashing	P. 87	
Low Oil Pressure Indicator	P. 87	
PGM-FI (Programmed Fuel Injection)		
Malfunction Indicator Lamp (MIL)	P. 87	
ABS (Anti-lock Brake System) Indicator	P. 88	
Other Warning Indications	P. 89	
Fuel Gauge Failure Indication	P. 89	
Tire Puncture	P. 90	
Electrical Trouble	P. 98	
Battery Goes Dead	P. 98	
Burned-out Light Bulb.....	P. 98	
		Blown Fuse..... P. 101

Starter Motor Operates But Engine Does Not Start

Check the following items:

- Check the correct engine starting sequence. ➔ P. 33
- Check that there is gasoline in the fuel tank.
- Check if the PGM-FI malfunction indicator lamp (MIL) is on.
 - ▶ If the indicator lamp is on, contact your dealer as soon as possible.

Starter Motor Does Not Operate

Check the following items:

- Check the correct engine starting sequence. ➔ P. 33
- Make sure engine stop switch is in the (Run) position. ➔ P. 30
- Check for a blown fuse. ➔ P. 101
- Check for a loose battery connection (➔ P. 58) or battery terminal corrosion (➔ P. 47).
- Check the condition of the battery. ➔ P. 98

If the problem continues, have your motorcycle inspected by your dealer.

Overheating (High oil temperature indicator is on)

The high oil temperature indicator may come on when idling or riding at very low speeds for a long time at high air temperature.

If the indicator comes on while idling or riding, stop the engine and let it cool down.

If the indicator remains on or lights again, take the motorcycle to your dealer as soon as possible.

NOTICE

Idling or riding with the indicator on may cause serious engine damage.

Low Oil Pressure Indicator

If the low oil pressure indicator comes on, pull safely to the side of the road and stop the engine.

NOTICE

Continuing to ride with low oil pressure can cause serious damage to the engine.

1. Check the engine oil level, and add oil as necessary. 📄 P. 65, 📄 P. 66
2. Start the engine.
 - ▶ Only continue riding if the low oil pressure indicator goes off.

Rapid acceleration may momentarily cause the low oil pressure indicator to come on, especially if the oil is at or near the low level. If the low oil pressure indicator stays on when the oil level is at the proper level, stop the engine and contact your dealer.

If the engine oil level goes down rapidly, your motorcycle may have a leak or another serious problem. Have your motorcycle inspected by your dealer.

PGM-FI (Programmed Fuel Injection) Malfunction Indicator Lamp (MIL)

If the indicator comes on while riding, you may have a serious problem with the PGM-FI system. Reduce speed and have your motorcycle inspected by your dealer as soon as possible.

ABS (Anti-lock Brake System) Indicator

If the indicator operates in one of the following ways, you may have a serious problem with the ABS. Reduce your speed and have your motorcycle inspected by your dealer as soon as possible.

- Indicator comes on or starts flashing while riding.
- Indicator does not come on when the ignition switch is in the ON position.
- Indicator does not go off at speeds above 10 km/h (6 mph).

If the ABS indicator stays on, your brakes will continue to work as a conventional system, but without the anti-locking function.

The ABS indicator may flash if you turn the rear wheel while your motorcycle is lifted off the ground. In this case, turn the ignition switch to the OFF position, and then to the ON position again. The ABS indicator will go off after your speed reaches 30 km/h (19 mph).

Fuel Gauge Failure Indication

If the fuel system has an error, the fuel gauge indicators will be displayed as shown in the illustrations.

If this occurs, see your dealer as soon as possible.

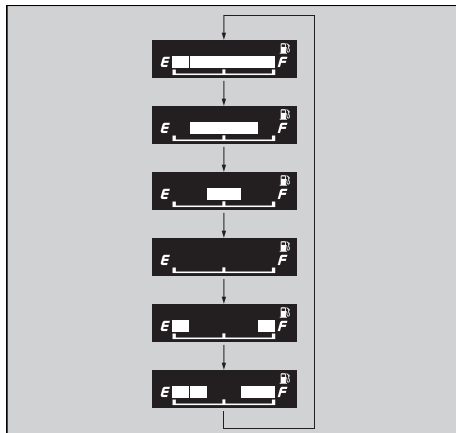
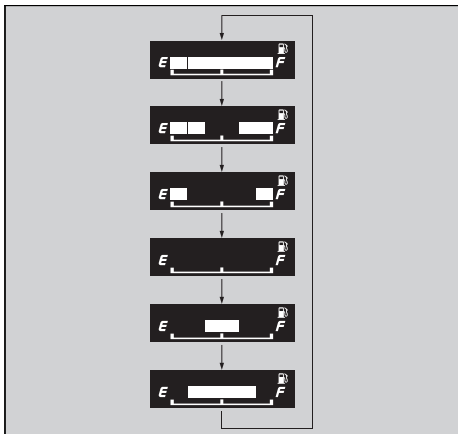

Repairing a puncture or removing a wheel requires special tools and technical expertise. We recommend you have this type of service performed by your dealer.

After an emergency repair, always have the tire inspected/replaced by your dealer.

Emergency Repair Using a Tire Repair Kit

If your tire has a minor puncture, you can make an emergency repair using a tubeless tire repair kit.

Follow the instructions provided with the emergency tire repair kit.

Riding your motorcycle with a temporary tire repair is very risky. Do not exceed 50 km/h (30 mph). Have the tire replaced by your dealer as soon as possible.

WARNING

Riding your motorcycle with a temporary tire repair can be risky. If the temporary repair fails, you can crash and be seriously injured or killed.

If you must ride with a temporary tire repair, ride slowly and carefully and do not exceed 50 km/h (30 mph) until the tire is replaced.

Removing Wheels

Follow these procedures if you need to remove a wheel in order to repair a puncture.

When removing and installing the wheel, be careful not to damage the wheel speed sensor and pulser ring.

Front Wheel

Removal

1. Place your motorcycle on its center stand on a firm, level surface.
2. Cover both sides of the front wheel and brake caliper with protective tape or cloth.

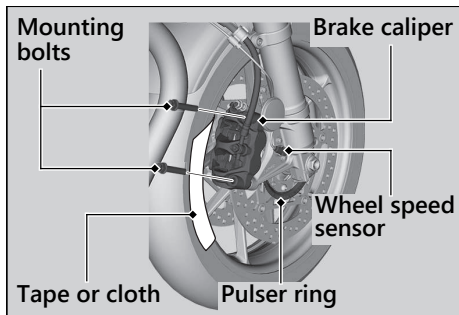

3. On the right side, remove the mounting bolts and remove the brake caliper.

4. On the left side, remove the mounting bolts and remove the brake caliper.
 - Support the brake caliper assemblies so that they don't hang from the brake hoses. Do not twist the brake hoses.
 - Avoid getting grease, oil, or dirt on the disc or pad surfaces.
 - Do not pull the brake lever while the brake caliper is removed.
 - Take care to prevent the brake calipers from scratching the wheel during removal.

5. Loosen the right axle pinch bolts.
6. Remove the front axle bolt.
7. Support your motorcycle securely and raise the front wheel off the ground using a maintenance stand or a hoist.

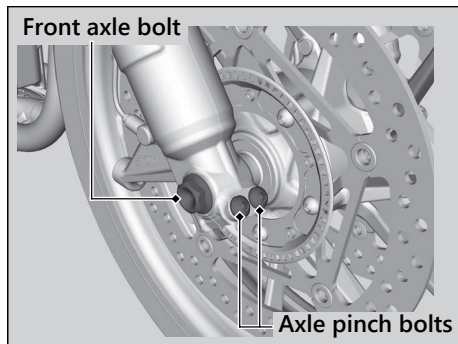

8. Loosen the left axle pinch bolts.
9. On the left side, withdraw the front axle shaft, and remove the side collars and wheel.

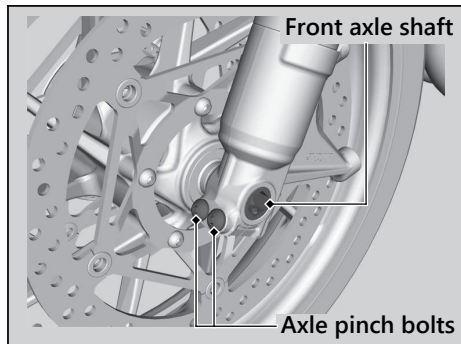

Installation

1. Attach the right and left side collars in their original locations on the wheel.
2. On the left side, place the wheel between the fork legs and insert the lightly greased front axle shaft to the end, through the left fork leg and wheel hub.
3. Align the end of the front axle shaft with the surface of the fork leg.

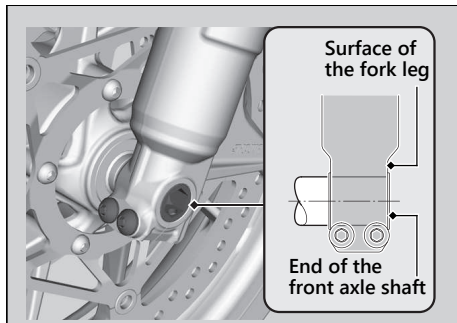

Tire Puncture ► Removing Wheels

4. Tighten the left axle pinch bolts to hold the axle.
5. Tighten the axle bolt.

Torque: 59 N·m (6.0 kgf·m, 44 lbf·ft).

6. Loosen the left axle pinch bolts.
7. Tighten the right axle pinch bolts.

Torque: 22 N·m (2.2 kgf·m, 16 lbf·ft).

8. Install the right and left brake calipers and tighten the mounting bolts.

Torque: 45 N·m (4.6 kgf·m, 33 lbf·ft).

- Take care to prevent the brake caliper from scratching the wheel during installation.
- Use new mounting bolts when installing the brake caliper.

NOTICE

When installing a wheel or caliper into original position, carefully fit the brake disc between the pads to avoid scratching them.

9. Lower the front wheel on the ground.
10. Apply the brake lever several times. Then, pump the fork several times.
11. Retighten the left axle pinch bolts.

Torque: 22 N·m (2.2 kgf·m, 16 lbf·ft).

12. Raise the front wheel off the ground again, and check that the wheel rotates freely after you release the brake.
13. Uncover the protective tape or cloth.

If a torque wrench was not used for installation, see your dealer as soon as possible to verify proper assembly. Improper assembly may lead to loss of braking capacity.

I Rear Wheel

Removal

1. Support your motorcycle securely and raise the rear wheel off the ground using the center stand or a hoist.
2. Loosen the rear axle nut, lock nuts and turn the adjusting bolts so the rear wheel can be moved all the way forward for maximum drive chain slack.
3. Release the rear axle nut/washer.

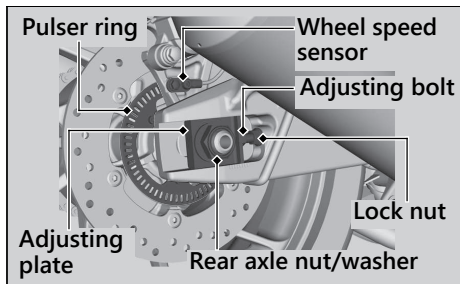

4. Remove the drive chain from the driven sprocket by pushing the rear wheel forward.
5. Remove the rear axle shaft and adjusting plates.

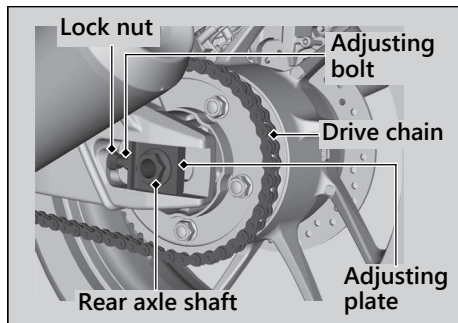

6. Remove the brake caliper bracket, rear wheel and side collars.
 - Support the brake caliper assembly so that it doesn't hang from the brake hose. Do not twist the brake hose.
 - Avoid getting grease, oil, or dirt on the disc to pad surfaces.
 - Do not push the brake pedal while the wheel is removed.

Installation

1. To install the rear wheel, reverse the removal procedure.
 - Take care to prevent the brake caliper from scratching the wheel during installation.

NOTICE

When installing a wheel or caliper into original position, carefully fit the brake disc between the pads to avoid scratching them.

2. Make sure that the lug on the brake caliper bracket is positioned in the slot on the swingarm.

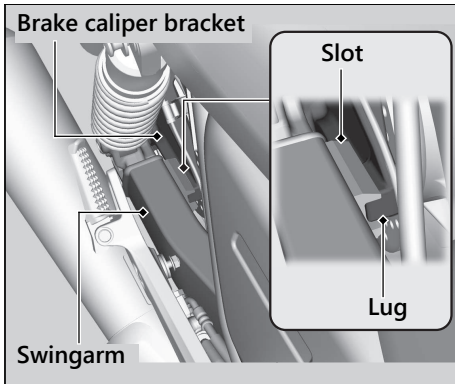

3. Adjust the drive chain. ► P. 75
4. After installing the wheel, apply the brake pedal several times, then check if the wheel rotates freely. Recheck the wheel if the brake drags or if the wheel does not rotate freely.

If a torque wrench was not used for installation, see your dealer as soon as possible to verify proper assembly. Improper assembly may lead to loss of braking capacity.

Battery Goes Dead

Charge the battery using a motorcycle battery charger.

Remove the battery from the motorcycle before charging.

Do not use an automobile-type battery charger, as these can overheat a motorcycle battery and cause permanent damage. If the battery does not recover after recharging, contact your dealer.

NOTICE

Jump starting using an automobile battery can damage your motorcycle's electrical system and is not recommended.

Bump starting is also not recommended.

Burned-out Light Bulb

Follow the procedure below to replace a burned-out light bulb.

Turn the ignition switch to the OFF or LOCK position.

Allow the bulb to cool before replacing it.

Do not use bulbs other than those specified.

Check the replacement bulb for correct operation before riding.

For the light bulb wattage, see "Specifications."  P. 126

| Headlight

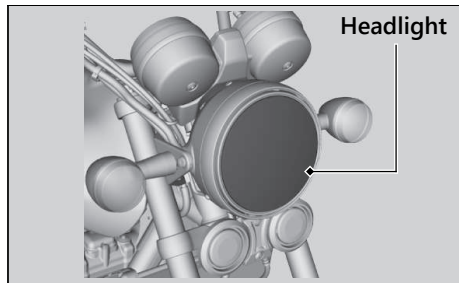

The headlight uses several LEDs. If there is a LED which is not turned on, see your dealer for this servicing.

| Brake light/Taillight

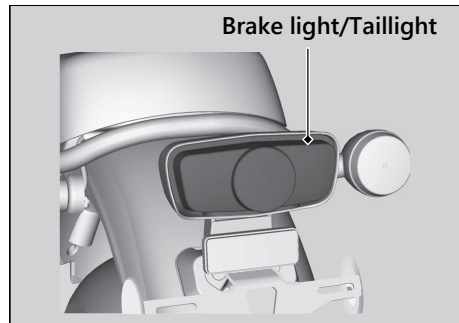

The brake light and taillight uses several LEDs. If there is a LED which is not turned on, see your dealer for this servicing.

Front/Rear Turn Signal Bulb

1. Remove the screw.
2. Turn the turn signal lens counterclockwise and remove it.
3. Slightly press the bulb and turn it counterclockwise.

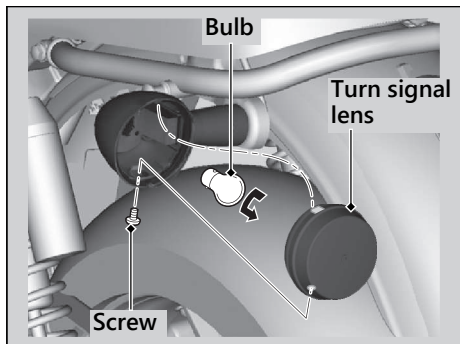

4. Install a new bulb and parts in the reverse order of removal.

Blown Fuse

Before handling fuses, see "Inspecting and Replacing Fuses." ► P. 49

Fuse Box Fuses

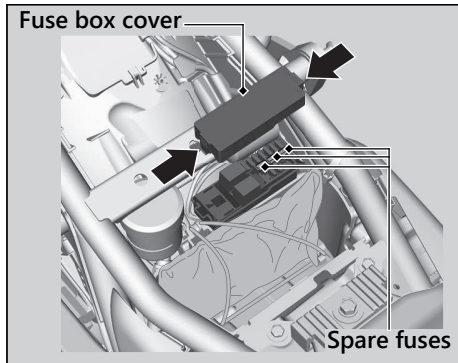

1. Remove the seat. ► P. 61
2. Remove the fuse box cover.
3. Pull the fuses out one by one with the fuse puller and check for a blown fuse. Always replace a blown fuse with a spare fuse of the same rating.
4. Reinstall the fuse box cover.
5. Reinstall the seat.

Main Fuse & FI Fuse

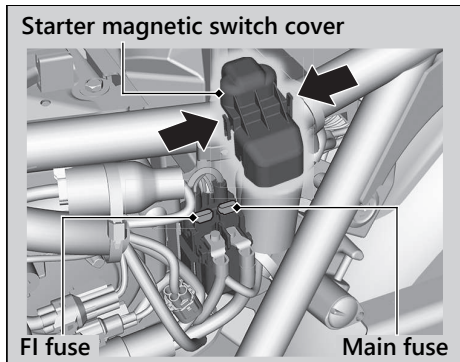

1. Remove the left side cover. ► P. 62
2. Remove the starter magnetic switch cover.
3. Pull the main fuse and FI fuse out one by one with the fuse puller and check for a blown fuse. Always replace a blown fuse with a spare fuse of the same rating.
► Spare fuses are provided in the fuse box. ► P. 101
4. Reinstall parts in the reverse order of removal.

NOTICE

If a fuse fails repeatedly, you likely have an electrical problem. Have your motorcycle inspected by your dealer.

Information

Keys.....	P. 104
Instruments, Controls, & Other Features...	P. 105
Caring for Your Motorcycle.....	P. 107
Storing Your Motorcycle.....	P. 111
Transporting Your Motorcycle.....	P. 112
You & the Environment.....	P. 112
Vehicle Identification Number.....	P. 113
Emission Control Systems.....	P. 114
Catalytic Converter.....	P. 118
Oxygenated Fuels.....	P. 119
Authorized Manuals.....	P. 120
Warranty Coverage and Service.....	P. 121
Honda Contacts.....	P. 123

Keys

Ignition Key

This motorcycle has two ignition keys and a key tag with a key number and a bar code. Store the spare key and the key tag in a safe location. To make a duplicate key, take the spare key and the key tag to your dealer or a locksmith. If you lose all keys and the key tag, the ignition switch assembly will probably have to be removed by your dealer to determine the key number.

A metal key holder may cause damage to the area surrounding the ignition switch.

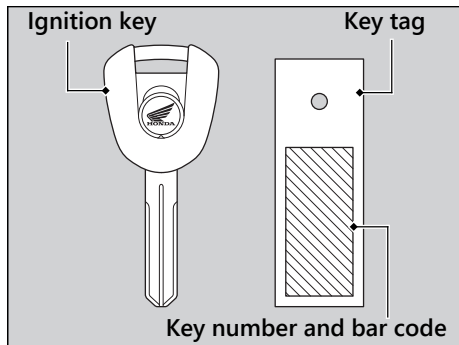

Instruments, Controls, & Other Features

Ignition Switch

Leaving the ignition switch in the ON position with the engine stopped will drain the battery.

Do not turn the key while riding.

Engine Stop Switch

Do not use the engine stop switch except in an emergency. Doing so when riding will cause the engine to suddenly turn off, making riding unsafe.

If you stop the engine using the engine stop switch, turn the ignition switch to the OFF position. Failing to do so will drain the battery.

Odometer

The display locks at 999,999 when the read-out exceeds 999,999.

Tripmeter

The tripmeters return to 0.0 when each read-out exceeds 9,999.9.

Document Bag

The owner's manual, registration, and insurance information can be stored in the plastic document bag located underside of the seat.

➤ P. 37

Ignition Cut-off System

A banking (lean angle) sensor automatically stops the engine and fuel pump if the motorcycle falls over. To reset the sensor, you must turn the ignition switch to the OFF position and back to the ON position before the engine can be restarted.

Assist-slipper Clutch System

The assist-slipper clutch system helps to prevent the rear tire from locking up when the deceleration of your motorcycle produces a strong engine braking effect. It also makes the clutch lever operation feel lighter.

Use only MA classification engine oil for your motorcycle. Using engine oil other than MA classification oil could result in damage to the assist-slipper clutch system.

Caring for Your Motorcycle

Frequent cleaning and polishing is important to ensure the life of your Honda. A clean motorcycle makes it easier to spot potential problems.

In particular, seawater and salts used to prevent ice on roads promote the formation of corrosion. Always wash your motorcycle thoroughly after riding on coastal or treated roads.

Washing

Allow the engine, muffler, brakes, and other high-temperature parts to cool before washing.

1. Rinse your motorcycle thoroughly using a low pressure garden hose to remove loose dirt.
2. If necessary, use a sponge or a soft towel with mild cleaner to remove road grime.
 - ▶ Clean the headlight lens, panels, and other plastic components with extra care to avoid scratching them.

Avoid directing water into the air cleaner, muffler, and electrical parts.

3. Thoroughly rinse your motorcycle with plenty of clean water and dry with a soft, clean cloth.
4. After the motorcycle dries, lubricate any moving parts.
 - ▶ Make sure that no lubricant spills onto the brakes or tires. Brake discs, pads, drum or shoes contaminated with oil will suffer greatly reduced braking effectiveness and can lead to a crash.
5. Lubricate the drive chain immediately after washing and drying the motorcycle.
6. Apply a coat of wax to prevent corrosion.
 - ▶ Avoid products that contain harsh detergents or chemical solvents. These can damage the metal, paint, and plastic on your motorcycle.
Keep the wax clear of the tires and brakes.
 - ▶ If your motorcycle has any matte painted parts, do not apply a coat of wax to the matte painted surface.

Washing Precautions

Follow these guidelines when washing:

- Do not use high-pressure washers:
 - ▶ High-pressure water cleaners can damage moving parts and electrical parts, rendering them inoperable.
 - ▶ Water in the air intake can be drawn into the throttle body and/or enter the air cleaner.
 - Do not direct water at the muffler:
 - ▶ Water in the muffler can prevent starting and causes rust in the muffler.
 - Dry the brakes:
 - ▶ Water adversely affects braking effectiveness. After washing, apply the brakes intermittently at low speed to help dry them.
 - Do not direct water under the seat:
 - ▶ Water in the under seat compartment can damage your documents and other belongings.
-
- Do not direct water at the air cleaner:
 - ▶ Water in the air cleaner can prevent the engine from starting.
 - Do not direct water near the headlight:
 - ▶ The headlight's inside lens may fog temporarily after washing or while riding in the rain. This does not impact the headlight function. However, if you see a large amount of water or ice accumulated inside the lens(es), have your vehicle inspected by your dealer.
 - Do not use wax or polishing compounds on matte painted surface:
 - ▶ Use a soft cloth or sponge, plenty of water, and a mild detergent to clean matte painted surfaces. Dry with a soft clean cloth.

Aluminum Components

Aluminum will corrode from contact with dirt, mud, or road salt. Clean aluminum parts regularly and follow these guidelines to avoid scratches:

- Do not use stiff brushes, steel wool, or cleaners containing abrasives.
- Avoid riding over or scraping against curbs.

Panels

Follow these guidelines to prevent scratches and blemishes:

- Wash gently using a soft sponge and plenty of water.
- To remove stubborn stains, use diluted detergent and rinse thoroughly with plenty of water.
- Avoid getting gasoline, brake fluid, or detergents on the instruments, panels, or headlight.

Exhaust Pipe and Muffler

The exhaust pipe and muffler are stainless steel but may become stained by mud or dust.

To remove mud or dust, use a wet sponge and a liquid kitchen abrasive, then rinse well with clean water. Dry with chamois or a soft towel.

If necessary, remove heat stains by using a commercially available fine texture compound. Then rinse by the same manner as removing mud or dust.

When the exhaust pipe and muffler are painted, do not use a commercially available abrasive kitchen cleaning compound. Use a neutral detergent to clean the painted surface on the exhaust pipe and muffler. If you are not sure if your exhaust pipe and muffler are painted, contact your dealer.

NOTICE

Even though the exhaust is made of stainless steel, it can become stained. Remove all marks and blemishes as soon as they are noticed.

Storing Your Motorcycle

If you store your motorcycle outdoors, you should consider using a full-body motorcycle cover.

If you won't be riding for an extended period, follow these guidelines:

- Wash your motorcycle and wax all painted surfaces (except matte painted surfaces). Coat chrome pieces with rust-inhibiting oil.
- Lubricate the drive chain. 📄 P. 52
- Place your motorcycle on its center stand and position a block so that both tires are off the ground.
- After rain, remove the body cover and allow the motorcycle to dry.
- Remove the battery (📄 P. 58) to prevent discharge. Fully charge the battery and then place it in a shaded, well-ventilated area.
 - ▶ If you leave the battery in place, disconnect the negative ⊖ terminal to prevent discharge.

After removing your motorcycle from storage, inspect all maintenance items required by the Maintenance Schedule.

For more information about storage, visit our website at www.honda.ca and look up "Storage Tips" under the "Honda Warranty" in the Warranty tab for your Model.

Transporting Your Motorcycle

If your motorcycle needs to be transported, it should be carried on a motorcycle trailer or a flatbed truck or trailer that has a loading ramp or lifting platform, and motorcycle tie-down straps. Never try to tow your motorcycle with a wheel or wheels on the ground.

NOTICE

Towing your motorcycle can cause serious damage to the transmission.

You & the Environment

Owning and riding a motorcycle can be enjoyable, but you must do your part to protect the environment.

Choose Sensible Cleaners

Use a biodegradable detergent when you wash your motorcycle. Avoid aerosol spray cleaners that contain chlorofluorocarbons (CFCs) which damage the atmosphere's protective ozone layer.

Recycle Wastes

Put oil and other toxic wastes in approved containers and take them to a recycling center. Call your local or state office of public works or environmental services to find a recycling center in your area, and to get instructions on how to dispose of non-recyclable wastes. Do not place used engine oil in the trash, or pour it down a drain or on the ground. Used oil, gasoline, and cleaning solvents contain poisons that can hurt refuse workers and contaminate drinking water, lakes, rivers, and oceans.

Vehicle Identification Number

The VIN and engine serial number uniquely identify your motorcycle and are required in order to register your motorcycle. They may also be required when ordering replacement parts.

You should record these numbers and keep them in a safe place.

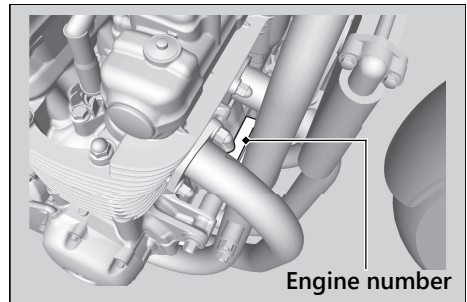
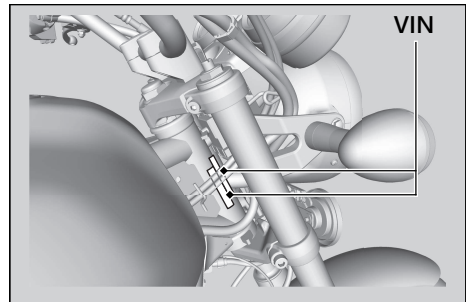

Emission Control Systems

Your motorcycle engine emits combustion byproducts, including carbon monoxide (CO), oxides of nitrogen (NOx), and hydrocarbons (HC). Gasoline evaporation also emits hydrocarbons. Controlling the production of NOx, CO, and HC is important for the environment.

Exhaust Emission Requirements

Environment and Climate Change Canada (ECCC) requires that your motorcycle comply with applicable exhaust, crankcase, and fuel permeation emission standards during its useful life, when operated and maintained according to the instructions provided.

The Vehicle Emission Control Information label is located right side of the swingarm.

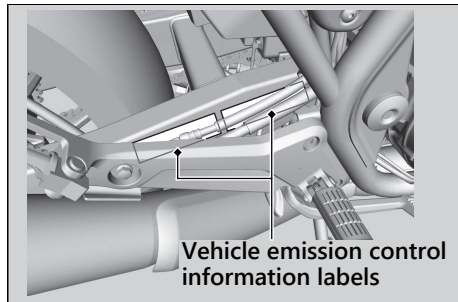

Exhaust Emission Control System

The exhaust emission control system includes the following components that should not need adjustment, although periodic inspection by your dealer is recommended.

PGM-FI System

The PGM-FI (programmed fuel injection) system uses sequential multiport fuel injection, and is comprised of air intake, engine control, fuel control, and exhaust control subsystems. The engine control module (ECM) uses sensors to determine how much air enters the engine, and then controls how much fuel to inject.

Ignition Timing Control System

The ignition timing control system adjusts the ignition timing to reduce the amount of HC, CO, and NO_x produced.

Secondary Air Injection System

The secondary air injection system adds filtered air into the exhaust gas to help improve emission control performance.

Catalytic Converters

The exhaust system contains one or more catalytic converters. Catalytic converters use a catalyst to convert most of the harmful exhaust gas compounds into harmless compounds.

Crankcase Emissions Control System

The engine is equipped with a closed crankcase system to prevent discharging crankcase emissions into the atmosphere. Blow-by gas is returned to the combustion chamber through the crankcase breather hose, air cleaner and throttle body.

Fuel Permeation Emission Control

The fuel tank, fuel hoses, and fuel vapor charge hoses use fuel permeation control technologies to prevent fuel vapor emissions. Tampering with these components to reduce or defeat the effectiveness of the fuel permeation technologies is prohibited.

Noise Emission Control System

■ TAMPERING WITH THE NOISE CONTROL SYSTEM IS PROHIBITED:

Canadian provincial laws may prohibit the following acts or the causing thereof: (1) The removal or rendering inoperative by any person, other than for purposes of maintenance, repair or replacement, of any device or element of design incorporated into any new vehicle for the purpose of noise control prior to its sale or delivery to the ultimate purchaser or while it is in use; or (2) the use of the vehicle after such device or element of design has been removed or rendered inoperative by any person.

AMONG THOSE ACTS PRESUMED TO CONSTITUTE TAMPERING ARE THE FOLLOWING ACTS:

- Removal of, or puncturing the muffler, baffles, header pipes or any other component which conducts exhaust gases.
- Removal of, or puncturing of any part of the intake system.
- Lack of proper maintenance.
- Removing or disabling any emissions compliance component, or replacing any compliance component with a noncompliant component.

Problems Affecting Motorcycle Exhaust Emissions

Have your motorcycle inspected and repaired by your dealer if you experience any of the following symptoms:

- Hard starting or stalling after starting
- Rough idling
- Misfiring or backfiring during acceleration
- Poor engine performance and poor fuel economy

Catalytic Converter

This motorcycle is equipped with two three-way catalytic converters. Each catalytic converter contains precious metals that serve as catalysts in high temperature chemical reactions that convert hydrocarbons (HC), carbon monoxide (CO), and oxides of nitrogen (NOx) in the exhaust gasses into safe compounds.

A defective catalytic converter contributes to air pollution and can impair your engine's performance. A replacement unit must be an original Honda part or equivalent.

Follow these guidelines to protect your motorcycle's catalytic converters.

- Always use unleaded gasoline. Leaded gasoline will damage the catalytic converters.
- Keep the engine in good running condition. A poorly running engine can cause the catalytic converter to overheat causing damage to the converter or the motorcycle.
- If your engine is misfiring, backfiring, stalling, or otherwise not running properly, stop riding and turn off the engine. Have your motorcycle serviced as soon as possible.

Oxygenated Fuels

Some conventional fuels blended with alcohol or an ether compound are available in some locales to help reduce emissions to meet clean air standards. These gasolines are collectively referred to as oxygenated fuels. If you plan to use oxygenated fuel, check that it is unleaded and meets the minimum octane rating and blend requirement.

The following fuel blends are EPA-approved and have been approved for use in your motorcycle:

- Ethanol (ethyl alcohol) up to 10% by volume.
 - ▶ Gasoline containing ethanol may be marketed under the name Gasohol.
- Methanol (methyl alcohol) up to 5% by volume that contain cosolvents and corrosion inhibitors to protect the fuel system. Never use a blend containing more than 5%.

If you accidentally fill your fuel tank with an oxygenated fuel containing higher percentages, you may experience performance problems. To resolve the problem, have your dealer drain the fuel tank and replace with the correct fuel. Fuel system or performance problems resulting from the use of an oxygenated fuel containing higher percentages are not covered by your warranty.

NOTICE

Improper use of oxygenated fuels can damage metal, rubber, and plastic parts of your fuel system.

Oxygenated fuel can also damage paint.

Damage caused by spilled fuel is not covered by warranty.

If you notice any undesirable operating symptoms or performance problems, try a different brand of gasoline.

Authorized Manuals

See your dealer to order authorized manuals.

Also available, but not necessary to service your model, is the Honda Common Service Manual, which explains basic service information for various systems on Honda motorcycles, scooters, and ATV.

These Honda manuals are written for the professional technician. However, if you possess the proper tools, observe the safety standards, and are mechanically capable, you should find them easy to use.

Special Honda tools are necessary for some procedures.

Publication Item No.	Description
61MGC03	2018 CB1100CA/NA Service Manual
61CSM00	Common Service Manual
31MGC630	2018 CB1100NA Owner's Manual

Warranty Coverage and Service

Coverage

Your new Honda is covered by the following warranties:

- Motorcycle Limited Warranty
- Emission Control System Warranty

There are responsibilities, restrictions, and exclusions which apply to these warranties. Please refer to the Warranty Booklet posted on our website at www.honda.ca.

It is important to realize that your warranty applies only to defects in material or workmanship of your Honda. Your warranty coverage does not apply to the normal wear and deterioration associated with use of the motorcycle.

Your warranty coverage is not voided if you perform your own maintenance. However, failures that occur due directly to improper maintenance are not covered by these warranties.

Almost all of your warranty coverage can be extended through the Honda Plus Protection Plan. For more information, see your dealer.

Warranty Coverage and Service

Service

Please remember that maintenance recommended in the Maintenance Schedule is not included in your warranty coverage. If you believe you have a problem with your motorcycle, call the service department of your Honda dealer. Make an appointment for an inspection and diagnosis. You will be asked to authorize that inspection, and your dealer will return the results of the inspection. If a problem exists and is covered under warranty, your dealer will perform the warranty repairs. If you have any questions about your warranty coverage or the nature of the repair, talk to the Service Manager of your Honda dealer.

If a misunderstanding occurs and you aren't satisfied with your dealer's handling of the situation, we suggest you discuss your problem with the appropriate member of the dealership's management team. If you are still not satisfied, contact the owner of the dealership or their designated representative.

Honda Contacts

Honda Canada Inc.

If you wish to contact Honda directly to comment on your experiences with your motorcycle or with your dealer, please send your comments to the following address:

Honda Canada Inc.

Customer Relations Department,

180 Honda Boulevard

Markham, Ontario

L6C 0H9

Telephone: (888)946-6329

Fax: (877) 939-0909

E-mail: honda_cr@ch.honda.com

Please include the following information in your letter:

- Name, address, and telephone number
- Product model, year, and VIN
- Date of purchase
- Dealer name and address

We will likely ask your Honda dealer to respond, or possibly acknowledge your comments directly.

Your Honda Dealer

The service department of your Honda dealer offers trained personnel to perform regular maintenance and most repairs. It has the latest available service information from Honda and also handles warranty inspections and repairs. The parts department offers Honda Genuine Parts, Pro Honda products, and Honda accessories and products that provide the same quality that went into your motorcycle. Your Honda dealer can also supply information about, riding events, and information about safety training available in your local area.

Specifications

■ Main Components

Overall length	2,200 mm (86.6 in)
Overall width	800 mm (31.5 in)
Overall height	1,100 mm (43.3 in)
Wheelbase	1,485 mm (58.5 in)
Minimum ground clearance	130 mm (5.1 in)
Caster angle	26° 00'
Trail	99 mm (3.9 in)
Curb weight	251 kg (553 lb)
Maximum weight capacity *1	159 kg (351 lb)
Passenger capacity	Rider and 1 passenger
Minimum turning radius	2.7 m (8.9 ft)
Displacement	1,140 cm ³ (69.5 cu-in)
Bore x stroke	73.5 x 67.2 mm (2.89 x 2.65 in)
Compression ratio	9.5:1
Fuel	Unleaded gasoline Recommended: 86 RON or higher
Tank capacity	16.8 L (4.44 US gal, 3.70 Imp gal)
Battery	YTZ14S 12 V-11.2 Ah (10 HR)

Gear ratio	1st	3.083
	2nd	1.941
	3rd	1.478
	4th	1.240
	5th	1.074
	6th	0.964
Reduction ratio (primary / final)	1.652 / 2.222	

*1: Including rider, passenger, all luggage, and accessories.

■ Service Data

Tire size	Front	120/70ZR17M/C (58W)
	Rear	180/55ZR17M/C (73W)
Tire type	Radial, tubeless	
Recommended tire	Front	BRIDGESTONE BATTLAX SPORT TOURING T30F J DUNLOP ROAD SMART III
	Rear	BRIDGESTONE BATTLAX SPORT TOURING T30R J DUNLOP ROAD SMART III
Tire air pressure	Front	250 kPa (2.50 kgf/cm ² , 36 psi)
	Rear	290 kPa (2.90 kgf/cm ² , 42 psi)
Minimum tread depth	Front	1.5 mm (0.06 in)
	Rear	2.0 mm (0.08 in)
Spark plug	(standard)	LMAR8A-9S (NGK)
Spark plug gap	0.8 - 0.9 mm (0.03 - 0.04 in)	
Idle speed	(non-adjustable)	1,100 ± 100 rpm
Recommended engine oil	API Service Classification SG or higher exceptoils labeled as energy conserving or resource conserving on the circular API service label, SAE 10W-30, JASO T 903 standard MA, Pro Honda GN4 4-stroke oil or Honda 4-stroke oil, or an equivalent motorcycle oil	

Engine oil capacity	After draining	3.8 L (4.0 US qt, 3.3 Imp qt)
	After draining & engine oil filter change	3.9 L (4.1 US qt, 3.4 Imp qt)
	After disassembly	4.9 L (5.2 US qt, 4.3 Imp qt)
Recommended brake (clutch) fluid	Honda DOT 4 Brake Fluid	
Recommended drive chain lubricant	Pro Honda HP Chain Lube or equivalent	
Drive chain slack	25 - 35 mm (1.0 - 1.4 in)	
Standard drive chain	DID50VA11 or RK50HFOZ6	
	No. of links	110
Standard sprocket size	Drive sprocket	18T
	Driven sprocket	40T

Specifications

■ Bulbs

Headlight	LED
Brake light/Taillight	LED
Front turn signal light	12 V-21 W × 2
Rear turn signal light	12 V-21 W × 2

■ Fuses

Main fuse	30 A
Other fuse	30 A, 20 A, 10 A

■ Torque Specifications

Oil filter	26 N·m (2.7 kgf·m, 19 lbf·ft)
Engine oil drain bolt	30 N·m (3.1 kgf·m, 22 lbf·ft)
Rear wheel axle nut	113 N·m (11.5 kgf·m, 83 lbf·ft)
Front wheel axle blot	59 N·m (6.0 kgf·m, 44 lbf·ft)
Front wheel brake caliper mounting bolt	45 N·m (4.6 kgf·m, 33 lbf·ft)
Front wheel axle pinch bolt	22 N·m (2.2 kgf·m, 16 lbf·ft)

Information Record

VIN	
Engine No.	
Color Label & Code	
Owner's Name	
Address	
City/State	
Phone	
Dealer's Name	
Address	
City/State	
Phone	
Service Manager	

- A**
- ABS (Anti-lock Brake System)**..... 10
 - ABS (Anti-lock Brake System)**
 - Indicator 27, 88
 - Accessories**..... 13
 - Air Cleaner**..... 69
- B**
- Battery**..... 47, 58
 - Brakes**
 - Fluid..... 51, 71
 - Lever Adjustment..... 81
 - Pad Wear 72
 - Braking**..... 10
 - Bulb**
 - Brake light/Taillight..... 99
 - Front Turn Signal Bulb..... 100
 - Headlight..... 99
 - Rear Turn Signal Bulb 100
- C**
- Caring for Your Motorcycle** 107
 - Catalytic Converter**..... 118
 - Clutch**
 - Fluid..... 77
 - Lever Adjustment..... 81
 - Clutch System**..... 77
 - Crankcase Breather** 79
- D**
- Digital Clock Adjustment**..... 25
 - Display Setting** 24
 - Drive Chain**..... 74
- E**
- Electrical Trouble** 98
 - Engine**
 - Number 113
 - Oil..... 50, 65
 - Oil Filter 67
 - Overheats..... 86
 - Starting 33
 - Stop Switch..... 105
 - Stopping 105
 - Will Not Start..... 85
 - Engine Stop Switch** 31
 - Environment** 112

Equipment

Helmet Holder	36
Owner's Manual	37, 105
Tool Kit.....	38

F

Front Suspension	82
-------------------------------	----

Fuel

Consumption Meter	20
Gauge	19
Mileage Meter	20
Recommended	35
Remaining.....	19
Tank Capacity	35

Fuses	49, 101
--------------------	---------

G

Gasohol	119
----------------------	-----

Gasoline	35
-----------------------	----

Gear Position Indicator	19
--------------------------------------	----

H

Hazard Switch	30
----------------------------	----

Headlight Aim	80
----------------------------	----

Headlight Dimmer Switch	30
--------------------------------------	----

Helmet Holder	36
----------------------------	----

High Beam Indicator	28
----------------------------------	----

High Oil Temperature Indicator	27
---	----

Honda Contacts	123
-----------------------------	-----

Horn Button	30
--------------------------	----

I

Ignition Cut-off System

Banking Sensor.....	106
---------------------	-----

Side Stand.....	73
-----------------	----

Ignition Key	104
---------------------------	-----

Ignition Switch	31, 33, 105
------------------------------	-------------

Indicators	27
-------------------------	----

Information Record	127
---------------------------------	-----

Instruments	18
--------------------------	----

L

Labels	7
---------------------	---

Load Limits	14
--------------------------	----

Loading Guidelines	14
---------------------------------	----

Low Oil Pressure Indicator	27, 87
---	--------

M	
Maintenance	
Fundamentals	44
Importance	40
Safety	40
Schedule.....	41
Maximum Weight Limit	14
Modifications.....	13
N	
Neutral Indicator	28
O	
Odometer	105
Oil	
Engine	50, 65
Overheating	86
Oxygenated Fuels.....	119
P	
Parking	11
Parts Location	16
Passing Light Control Switch	30
PGM-FI (Programmed Fuel Injection)	
Malfunction Indicator Lamp (MIL).....	28, 87
Protective Apparel.....	8
R	
Rear Suspension.....	83
Recommended	
Fuel	35
Oil	50
Refueling.....	35
Removal	
Battery.....	58
Clip.....	60
Seat.....	61
Side Cover	62
Repair Kit	90
Riding Precautions	9
S	
Safety Labels	7
Safety Precautions.....	8
Shifting Gears	34
Side Stand.....	73
Side Stand Ignition Cut-off System	73

Spark Plugs	63
Specifications	124
Speedometer	18
Start Button	30, 33
Starting the Engine	33
Steering Lock	32
Stopping Engine	105
Storage	
Equipment	36
Helmet Holder	36
Owner's Manual	37, 105
Tool Kit.....	38
Storing Your Motorcycle	111
Switches	30
 T	
Tachometer	18
Throttle	78
Tires	
Air Pressure	54
Puncture	90
Replacing.....	56, 90
Transporting Your Motorcycle	112
Tripmeter	20, 105

Troubleshooting	84
Turn Signal Indicator	28

V

Vehicle Identification Number	113
--	-----

W

Warning Indicators On or Flashing	87
Warranty Coverage and Service	121
Washing Your Motorcycle	107
Weight Limit	14

Wheels

Front Removal	91
Rear Removal.....	95

HONDA
The Power of Dreams

31MGC630
00X31-MGC-6300

英 AB 400.2017.09.J
PRINTED IN JAPAN